

EQP274X-2D

40G QSFP+ LR4 Optical Transceiver

PRODUCT FEATURES

- Support line rates for 41.25 Gb/s
- Lane bit rate 10.3125 Gb/s
- CWDM DML laser and PIN ROSA
- Up to 2km transmission on SMF
- Support Multi-Pin function with IntL/RxLOSL and LPMode/TxDIS
- I2C interface with integrated Digital Diagnostic monitoring;
- Digital Diagnostics Monitoring Interface
- Compliant with QSFP+ MSA with LC connector
- Single +3.3V power supply
- Power dissipation:
 - Commercial: < 3.5W
 - Industrial: <4.5W
- Complies with EU Directive 2015/863/EU

APPLICATIONS

- 40G Ethernet
- InfiniBand QDR, DDR and SDR

DESCRIPTIONS

40G QSFP+ LR4 Transceiver is designed for 2km optical communication applications. This module contains 4-lane optical transmitter, 4-lane optical receiver and module management block including 2 wire serial inter-face. The optical signals are multiplexed to a single-mode fiber through an industry standard LC connector.

Module Block Diagram

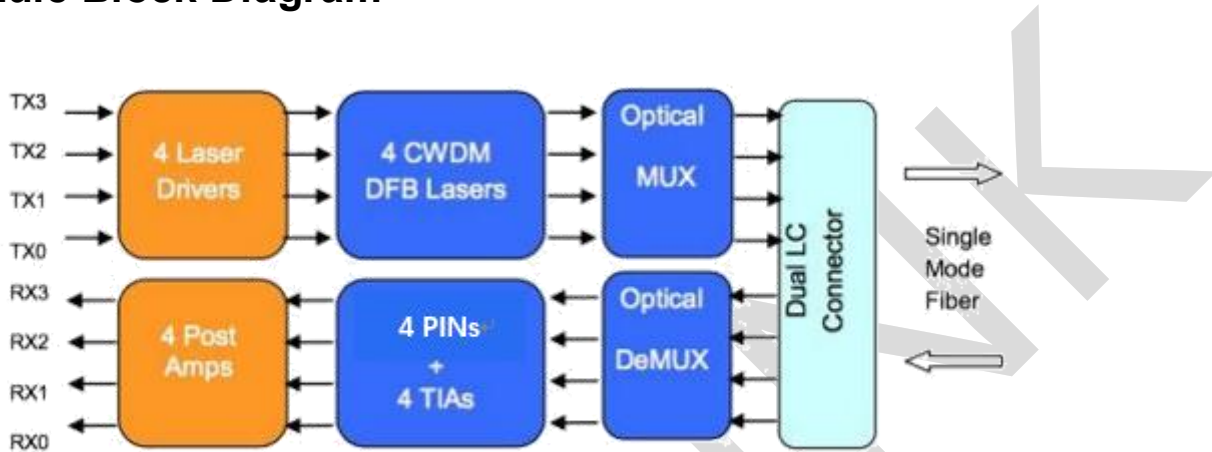

Ordering Information

Part No.	Data Rate(optical)	Laser	Fiber Type	Distance	Optical Interface	Temp	DDMI	Latch Color
EQP274X-2D	41.25Gbps	DFB	SMF	2km	LC	0~70°C	Yes	Blue

Absolute Maximum Ratings

It has to be noted that the operation in excess of any individual absolute maximum ratings might cause permanent damage to this module.

Parameter	Symbol	Min	Max	Unit	Notes
Storage Temperature	TS	-40	85	degC	
Operating Case Temperature	TOP	0	70	degC	
Power Supply Voltage	VCC	-0.5	3.6	V	
Relative Humidity (non-condensation)	RH	0 to 85% non-condensing		%	

Recommended Operating Conditions

Parameter	Symbol	Min	Typ	Max	Unit	Notes
Operating Case Temperature	Top	0		+70	°C	
Operating Case Temperature	VCC	3.14	3.3	3.47	V	

Maximum Power Dissipation	P_D			3.5	W	
Lane Bit Rate			10.3125		Gb/s	
Transmission Distance	TD			2	km	
Coupled fiber	Single mode fiber					1

Notes:

1. Optical fiber use 9/125um SMF。

Electrical Characteristics

The following electrical characteristics are defined over the Recommended Operating Environment unless otherwise specified.

Parameter	Test Point	Min	Typ	Max	Unit	Notes
Transmitter (Module Input)						
Data Rate, each lane			10.3125		Gbps	
Differential Voltage pk-pk	V_{pp}			900	mV	1
Common Mode Voltage	V_{cm}	-350		2850	mV	
Transition time	T_{rise}/T_{fall}	10			ps	2
Receiver (Module Output)						
Data Rate, each lane			10.3125		Gbps	
Common Mode Noise, RMS	V_{rms}			17.5	mV	
Differential output voltage swing	$V_{out, pp}$			900	mV	
Eye width	EW15	0.57			UI	
Eye height	EH15	228			mV	
Differential Termination Resistance Mismatch				10	%	1
Transition time	T_{rise}/T_{fall}	12			ps	
Data Rate, each lane			10.3125		Gbps	
Common Mode Noise, RMS	V_{rms}			17.5	mV	

Optical and Characteristics

Parameter	Symbol	Min	Typ	Max	Unit	Note
Transmitter						
Signaling Speed per Lane			10.3125		Gbps	
Center Wavelength Lane 0	λ_0	1264.5	1271	1277.5	nm	
Center Wavelength Lane 1	λ_1	1284.5	1291	1297.5	nm	
Center Wavelength Lane 2	λ_2	1304.5	1311	1317.5	nm	
Center Wavelength Lane 3	λ_3	1324.5	1331	1337.5	nm	

Total Launch Power	P_T			8.3	dBm	1
Average Launch Power per Lane,	P_{avg}	-7		2.3	dBm	1
Difference in launch power between any two lanes(Average and OMA) between any Two Lanes (OMA)	$P_{tx,diff}$			6.5	dB	
Average Output Power (Laser Turn off)	P_{off}			-30	dBm	
Side Mode Suppression Ratio	SMSR	30			dB	
Extinction Ratio,	ER	3.5			dB	
RIN20OMA	RIN			-128	Db/Hz	
Optical Return Loss Tolerance	TOL			20	dB	
Transmitter Reflectance	R_T			-12	dB	
Optical Eye Mask	{0.25,0.4, 0.45, 0.25, 0.28, 0.4}				%	2
Receiver						
Signaling rate, each lane			10.3125		Gbps	
Center Wavelength Lane 0	λ_0	1264.5	1271	1277.5	nm	
Center Wavelength Lane 1	λ_1	1284.5	1291	1297.5	nm	
Center Wavelength Lane 2	λ_2	1304.5	1311	1317.5	nm	
Center Wavelength Lane 3	λ_3	1324.5	1331	1337.5	nm	
Damage threshold , each lane	P_{damage}	3.3			dBm	
Receiver sensitivity Average, each lane	SEN			-11.5	dBm	2
Los Assert	LosA	-30			dBm	
Los De-assert	LosDA			-14	dBm	

Notes:

- 1.The optical power is launched into SMF。
- 2.Measured with a PRBS 231-1 test pattern @10.3125 Gb/s, PRBS 2³¹-1

Digital Diagnostics

Parameter	Range	Unit	Accuracy	Calibration
Temperature	-40 to +85	°C	±3°C	Internal / External
Voltage	3.0 to 3.6	V	±3%	Internal / External
Bias Current	30 to 100	mA	±10%	Internal / External
TX Power	-7 to 2.3	dBm	±3dB	Internal / External
RX Power	-11.5 to 2.3	dBm	±3dB	Internal / External

Pin Diagram

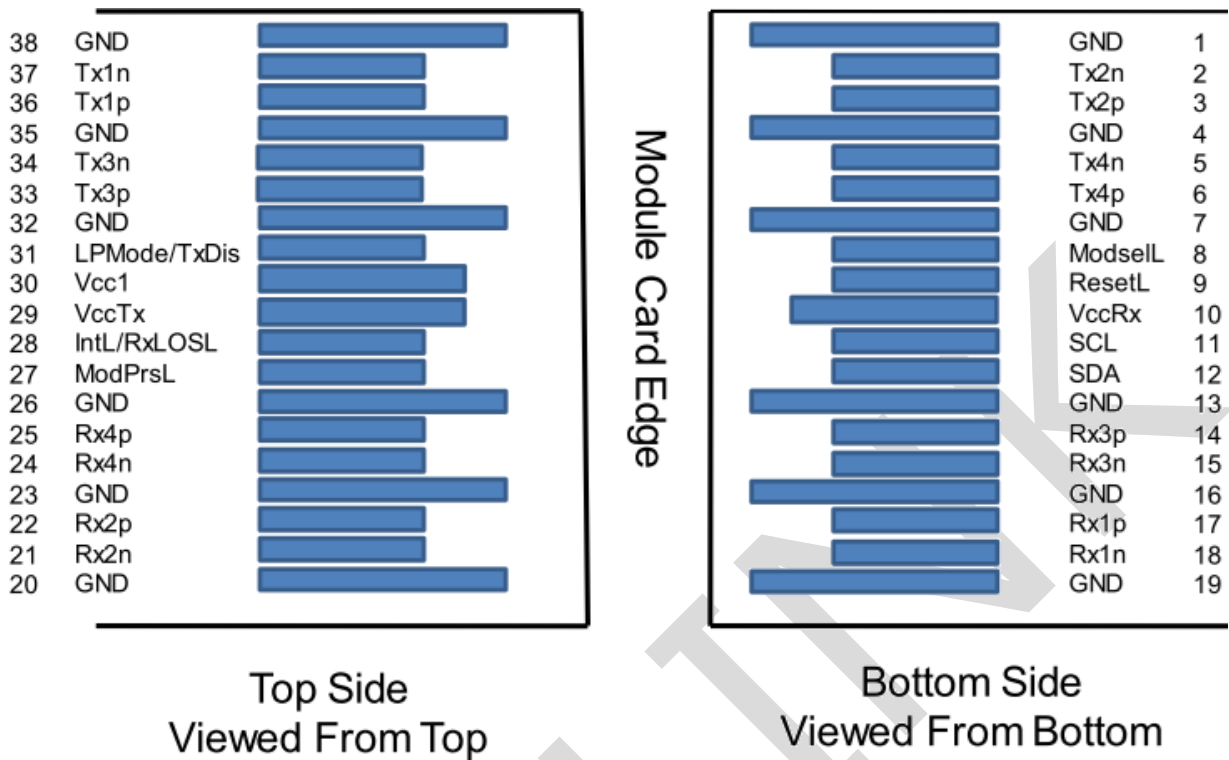

Pin Definitions

PIN	Logic	Symbol	Description	Plug Seq.	Notes
1		GND	Ground	1	1
2	CML-I	Tx2n	Transmitter Inverted Data Input	3	
3	CML-I	Tx2p	Transmitter Non-Inverted Data output	3	
4		GND	Ground	1	1
5	CML-I	Tx4n	Transmitter Inverted Data Input	3	
6	CML-I	Tx4p	Transmitter Non-Inverted Data output	3	
7		GND	Ground	1	1
8	LVTLL-I	ModSelL	Module Select	3	
9	LVTLL-I	ResetL	Module Reset	3	
10		VccRx	+ 3.3V Power Supply Receiver	2	2
11	LVC MOS-I/O	SCL	2-Wire Serial Interface Clock	3	
12	LVC MOS-I/O	SDA	2-Wire Serial Interface Data	3	
13		GND	Ground	1	

14	CML-O	Rx3p	Receiver Non-Inverted Data Output	3	
15	CML-O	Rx3n	Receiver Inverted Data Output	3	
16		GND	Ground	1	1
17	CML-O	Rx1p	Receiver Non-Inverted Data Output	3	
18	CML-O	Rx1n	Receiver Inverted Data Output	3	
19		GND	Ground	1	1
20		GND	Ground	1	1
21	CML-O	Rx2n	Receiver Inverted Data Output	3	
22	CML-O	Rx2p	Receiver Non-Inverted Data Output	3	
23		GND	Ground	1	1
24	CML-O	Rx4n	Receiver Inverted Data Output	3	1
25	CML-O	Rx4p	Receiver Non-Inverted Data Output	3	
26		GND	Ground	1	1
27	LVTTTL-O	ModPrsL	Module Present	3	
28	LVTTTL-O	IntL/Rx_LOS	Interrupt/Rx_LOS	3	
29		VccTx	+3.3 V Power Supply transmitter	2	2
30		Vcc1	+3.3 V Power Supply	2	2
31	LVTTTL-I	LPMoDe/TxDIS	Low Power Mode/Tx_Disable	3	
32		GND	Ground	1	1
33	CML-I	Tx3p	Transmitter Non-Inverted Data Input	3	
34	CML-I	Tx3n	Transmitter Inverted Data Output	3	
35		GND	Ground	1	1
36	CML-I	Tx1p	Transmitter Non-Inverted Data Input	3	
37	CML-I	Tx1n	Transmitter Inverted Data Output	3	
38		GND	Ground	1	1

Notes:

1. GND is the symbol for signal and supply (power) common for the QSFP+ module. All are common within the QSFP+ module and all module voltages are referenced to this potential unless otherwise noted. Connect these directly to the host board signal-common ground plane.
2. Vcc Rx, Vcc1 and Vcc Tx are the receiver and transmitter power supplies and shall be applied concurrently. Requirements defined for the host side of the Host Edge Card Connector are listed in MSA. The connector pins are each rated for a maximum current of 1000 mA.

Recommended Interface Circuit

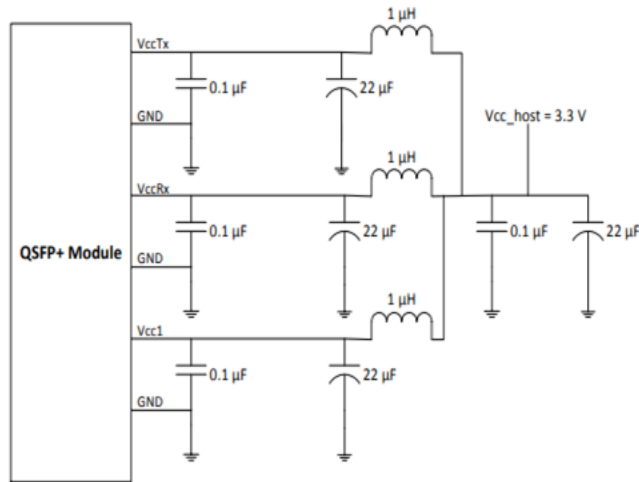
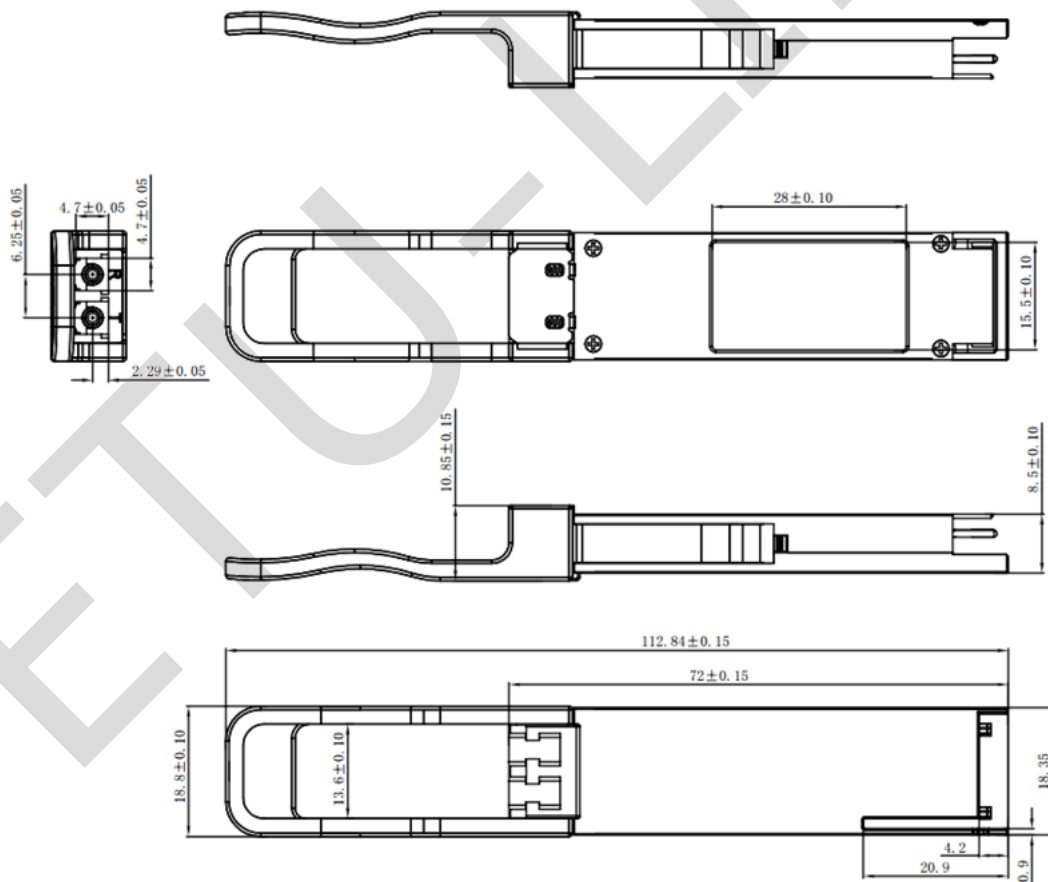

FIGURE 5-4 RECOMMENDED HOST BOARD POWER SUPPLY FILTERING

Mechanical Diagram



Revision History

Version No.	Date	Description
1.0	Aug 24, 2021	Preliminary datasheet
2.0	October 11,2023	Product upgrades
2.1	Aug 06,2024	Format change

Company: ETU-Link Technology Co., LTD

Production base: Right side of 3rd floor, No. 102 building, Longguan expressway, Dalang street, Longhua District, Shenzhen city, Guangdong Province, China 518109

R&D base: Floor 4, Building 4, Nanshan Yungu Phase LI, Taoyuan Community, XiliStreet, Nanshan District, Shenzhen

Tel: +86-755 2328 4603

Addresses and phone number also have been listed at www.etulinktechnology.com.

Please e-mail us at sales@etulinktechnology.com or call us for assistance.