

EQP29Y-80D(I)

100G QSFP28 ZR4 Optical Transceiver

PRODUCT FEATURES

- Support line rates from 103.125 Gb/s;
- Lane bit rate 25.78 Gb/s 100GE
- Up to 80km transmission with KR4-FEC.
- Optical specifications are compliant with IEEE802.3ba 100GBASE-ZR4.
- LAN WDM EML laser and PIN receiver with SOA;
- Support Multi-Pin function with IntL/RxLOSL and LPMode/TxDIS;
- High speed I/O electrical interface (CAUI-4);
- I2C interface with integrated Digital Diagnostic monitoring;
- QSFP28 MSA package with duplex LC connector;
- Single +3.3V power supply
- Power dissipation
- Commercial: < 4.5W
- Industrial: <5.5W
- Complies with EU Directive 2015/863/EU
- Monitor transceiver power and warn when threshold is exceeded

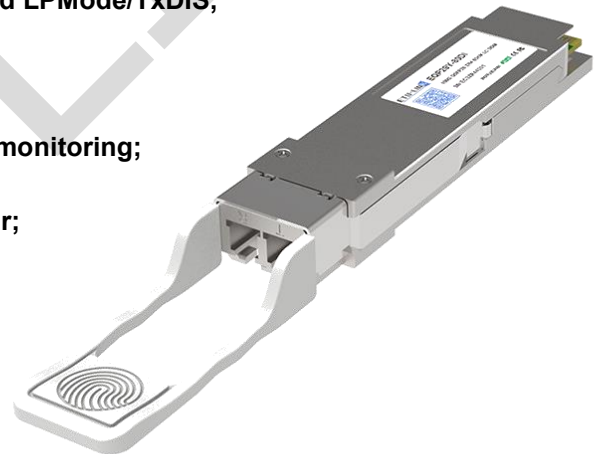

APPLICATIONS

- 100GBASE-ZR4 Ethernet
- 100G Datacom& Telecom connections

DESCRIPTIONS

ETU-LINK's EQP29Y-80D(I) is designed for 80km optical communication applications. Optical transceiver integrates the transmit and receive path onto one module. On the transmit side, four lanes of serial data streams are recovered, retimed, and passed on to four laser drivers, which control four electric-absorption modulated lasers (Lan-WDM) with 1296, 1300, 1305, and 1309 nm center wavelengths. The optical signals are then multiplexed into a single-mode fiber through an industry-standard LC connector. On the receive side, four lanes of optical data streams are optically DE multiplexed by an integrated optical DE multiplexer. After the optical signal is amplified by SOA, DEMUX separates four channels which are recovered by PIN photodetector and cross-impedance amplifier, retimed and passed on to an output driver. This module features a hot-pluggable electrical interface, low power consumption, and 2-wire serial interface.

Module Block Diagram

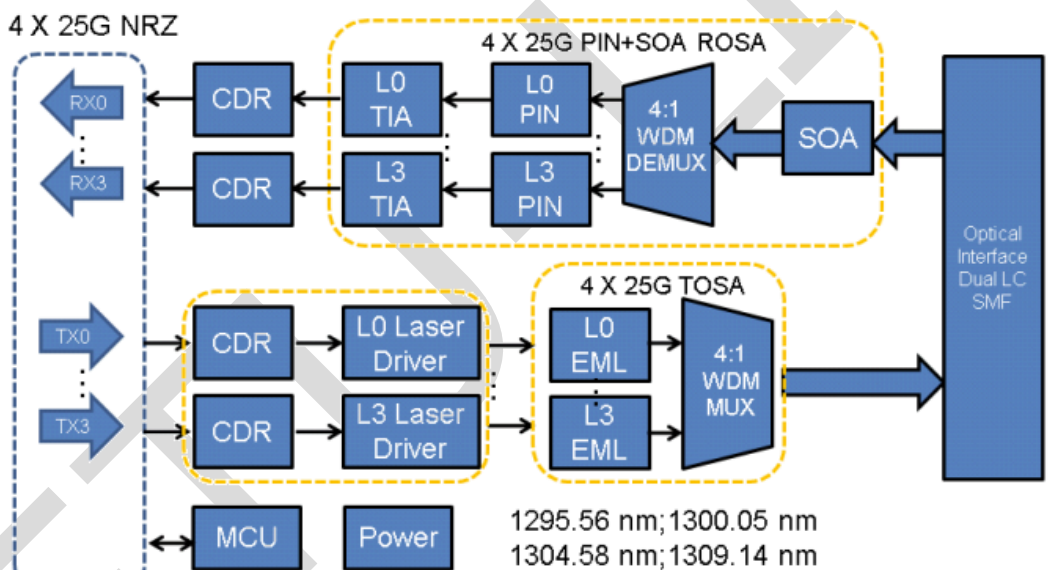

Ordering Information

Part No.	Data Rate(optical)	Laser	Fiber Type	Distance	Optical Interface	Temp	DDMI	Latch Color
EQP29Y-80D	103.125Gbps	EML	SMF	80km	LC	0~70°C	Yes	White
EQP29Y-80DI	103.125Gbps	EML	SMF	80km	LC	-20~85°C	Yes	White

Absolute Maximum Ratings

It has to be noted that the operation in excess of any individual absolute maximum ratings might cause permanent damage to this module.

Parameter	Symbol	Min	Max	Unit	Notes
Storage Temperature	TS	-40	85	degC	
Operating Case Temperature	TOP	-40	85	degC	
Power Supply Voltage	VCC	-0.5	3.6	V	
Damage Threshold, each Lane	THd	5.5		dBm	
RelativeHumidity (non-condensation)	RH	0 to 85% non-condensing		%	

The following characteristics are defined over the Recommended Operating Environment unless otherwise specified.

Recommended Operating Conditions

Parameter	Symbol	Min.	Typical	Max.	Unit	Notes
Case Operating Temperature	Top	0	-	70	°C	Commercial
		-40		85		Industrial
Power Supply Voltage	V _{CC}	3.13	3.3	3.47	V	
Transmission Distance	TD	-	-	80	km	Over SMF

Electrical Characteristics

The following electrical characteristics are defined over the Recommended Operating Environment unless otherwise specified.

Parameter	Test Point	Min	Typ	Max	Unit	Notes
Transmitter (Module Input)						
Data Rate, each lane			25.78125		Gbps	
Differential Voltage pk-pk	V _{pp}			900	Mv	1
Common Mode Voltage	V _{cm}	-350		2850	Mv	
Transition time	Trise/Tfall	10			ps	2
Receiver (Module Output)						
Data Rate, each lane					25.78125	
Common Mode Noise, RMS	V _{rms}			17.5	mV	
Differential output voltage swing	V _{out, pp}			900	mV	
Eye width	EW15	0.57			UI	

Eye height	EH15	228			mV	
Differential Termination Resistance Mismatch				10	%	1
Transition time	Trise/Tfall	12			ps	
Data Rate, each lane			25.78125		Gbps	
Common Mode Noise, RMS	Vrms			17.5	mV	

Notes:

1. At 1 MHz.
2. 20%~80%.

Optical and Characteristics

Parameter	Symbol	Min	Typ	Max	Unit	Note
Transmitter						
Signaling Speed per Lane			25.78125		Gbps	
Center Wavelength Lane 0	λ_0	1294.53	1295.56	1296.59	nm	
Center Wavelength Lane 1	λ_1	1299.02	1300.05	1301.09	nm	
Center Wavelength Lane 2	λ_2	1303.54	1304.58	1305.63	nm	
Center Wavelength Lane 3	λ_3	1308.09	1309.14	1310.19	nm	
Total Launch Power, 100GE	P_T	7		12.5	dBm	1
Average Launch Power per Lane,	P_{avg}	1		6.5	dBm	1
OMA, each Lane	P_{OMA}	2		6.5	dBm	1
Difference in launch power between any two lanes(Average and OMA) between any Two Lanes (OMA)	$P_{tx,diff}$			3	dB	
Average Output Power (Laser Turn off)	P_{off}			-30	dBm	
Side Mode Suppression Ratio	SMSR	30			dB	
Extinction Ratio, 100GE	ER	8.2			dB	
RIN20OMA	RIN			-130	dB/Hz	
Optical Return Loss Tolerance	TOL			20	dB	
Transmitter Reflectance	R_T			-12	dB	
Optical Eye Mask		{0.25,0.4, 0.45, 0.25, 0.28, 0.4}			%	2
Receiver						
Signaling rate, each lane			25.78125		Gbps	
Center Wavelength Lane 0	λ_0	1294.53	1295.56	1296.59	nm	
Center Wavelength Lane 1	λ_1	1299.02	1300.05	1301.09	nm	
Center Wavelength Lane 2	λ_2	1303.54	1304.58	1305.63	nm	
Center Wavelength Lane 3	λ_3	1308.09	1309.14	1310.19	nm	

Damage threshold , each lane	Pdamage	5.5			dBm	
Receiver sensitivity Average, each lane	SEN			-28	dBm	3
Los Assert	LosA	-40			dBm	
Los De-assert	LosDA			-28	dBm	

Notes:

- 1.The optical power is launched into SMF。
- 2.Measured with a PRBS 231-1 test pattern @25.78125, Hit ratio≤5E-5。
- 3.Measured with a PRBS 231-1 test pattern @25.78125 Gb/s, BER≤5E-5。

Digital Diagnostics

Parameter	Unit	Specification
Temperature Monitor absolute error	°C	± 3.0
Supply Voltage Monitor absolute error	%	± 5°C
I_bias Monitor absolute error	%	± 10
Received Power (Rx) Monitor absolute error	dB	± 3.0
Transmit Power (Tx) Monitor absolute error	dB	± 3.0

Pin Diagram

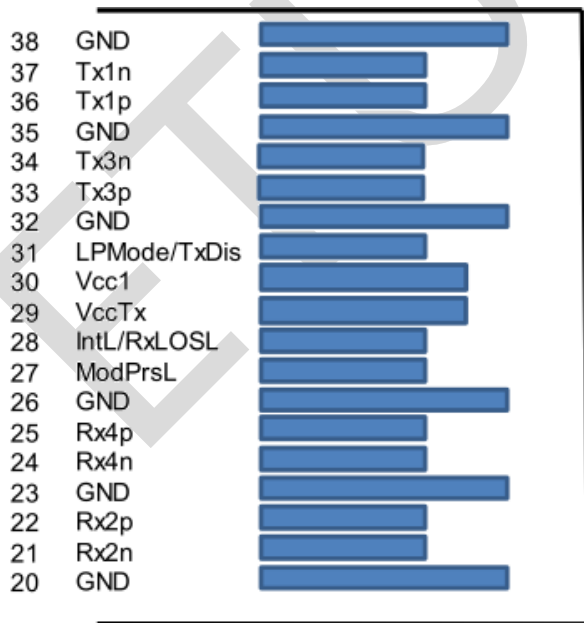

Top Side
Viewed From Top

Module Card Edge

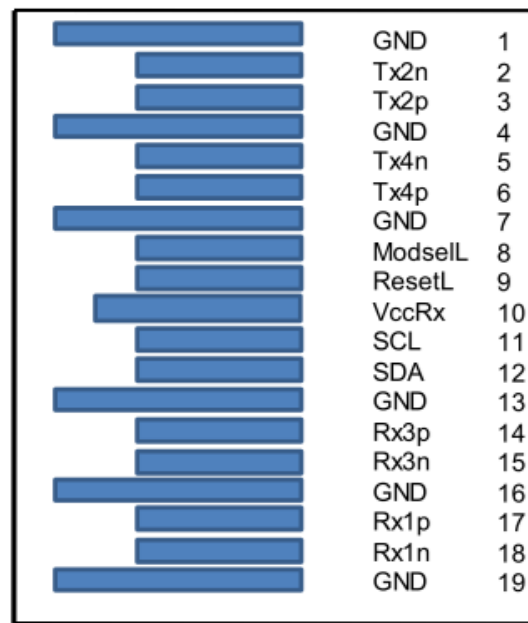

Bottom Side
Viewed From Bottom

Pin Definitions

PIN	Logic	Symbol	Description	Plug Seq.	Notes
1		GND	Ground	1	1
2	CML-I	Tx2n	Transmitter Inverted Data Input	3	
3	CML-I	Tx2p	Transmitter Non-Inverted Data output	3	
4		GND	Ground	1	1
5	CML-I	Tx4n	Transmitter Inverted Data Input	3	
6	CML-I	Tx4p	Transmitter Non-Inverted Data output	3	
7		GND	Ground	1	1
8	LVTTLL-I	ModSelL	Module Select	3	
9	LVTTLL-I	ResetL	Module Reset	3	
10		VccRx	+ 3.3V Power Supply Receiver	2	2
11	LVCNOS-I/O	SCL	2-Wire Serial Interface Clock	3	
12	LVCNOS-I/O	SDA	2-Wire Serial Interface Data	3	
13		GND	Ground	1	
14	CML-O	Rx3p	Receiver Non-Inverted Data Output	3	
15	CML-O	Rx3n	Receiver Inverted Data Output	3	
16		GND	Ground	1	1
17	CML-O	Rx1p	Receiver Non-Inverted Data Output	3	
18	CML-O	Rx1n	Receiver Inverted Data Output	3	
19		GND	Ground	1	1
20		GND	Ground	1	1
21	CML-O	Rx2n	Receiver Inverted Data Output	3	
22	CML-O	Rx2p	Receiver Non-Inverted Data Output	3	
23		GND	Ground	1	1
24	CML-O	Rx4n	Receiver Inverted Data Output	3	1
25	CML-O	Rx4p	Receiver Non-Inverted Data Output	3	
26		GND	Ground	1	1
27	LVTTTL-O	ModPrsL	Module Present	3	
28	LVTTTL-O	IntL/Rx_LOS	Interrupt/Rx_LOS	3	
29		VccTx	+3.3 V Power Supply transmitter	2	2
30		Vcc1	+3.3 V Power Supply	2	2
31	LVTTTL-I	LPMODE/TxDIS	Low Power Mode/Tx_Disable	3	

32		GND	Ground	1	1
33	CML-I	Tx3p	Transmitter Non-Inverted Data Input	3	
34	CML-I	Tx3n	Transmitter Inverted Data Output	3	
35		GND	Ground	1	1
36	CML-I	Tx1p	Transmitter Non-Inverted Data Input	3	
37	CML-I	Tx1n	Transmitter Inverted Data Output	3	
38		GND	Ground	1	1

Notes:

1. GND is the symbol for signal and supply (power) common for the QSFP28 module. All are common within the QSFP28 module and all module voltages are referenced to this potential unless otherwise noted. Connect these directly to the host board signal-common ground plane.
2. Vcc Rx, Vcc1 and Vcc Tx are the receiver and transmitter power supplies and shall be applied concurrently. Requirements defined for the host side of the Host Edge Card Connector are listed in MSA. The connector pins are each rated for a maximum current of 1000 Ma

Recommended Interface Circuit

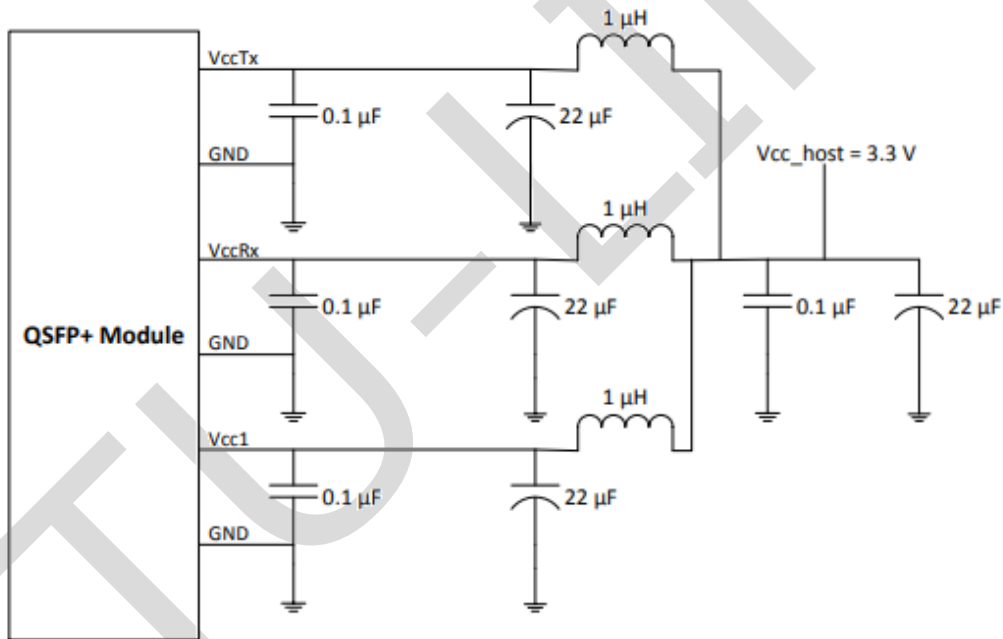
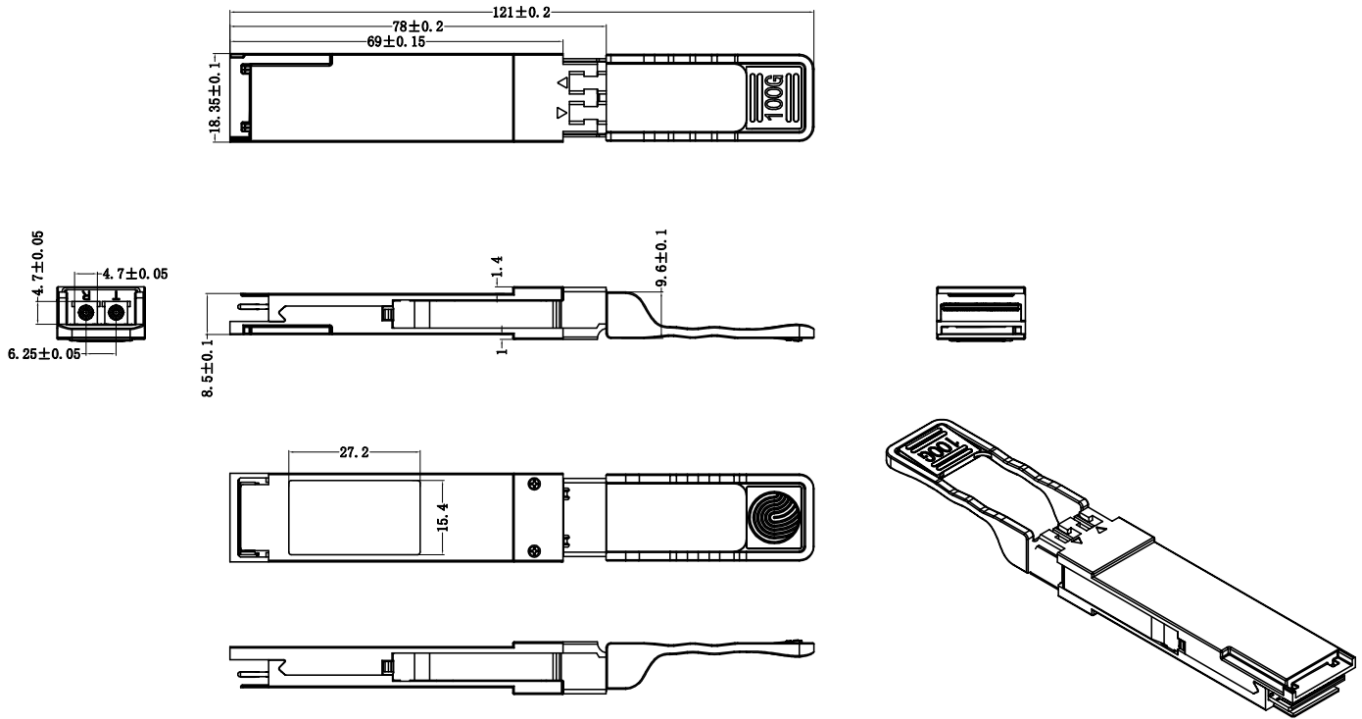

FIGURE 5-4 RECOMMENDED HOST BOARD POWER SUPPLY FILTERING

Mechanical Diagram



Revision History

Version No.	Date	Description
1.0	Aug 14, 2022	Preliminary datasheet
2.0	October 11, 2023	Product upgrades
2.1	July 17, 2024	Format change

Company: ETU-Link Technology Co., LTD

Production base: Right side of 3rd floor, No. 102 building, Longguan expressway, Dalang street, Longhua District, Shenzhen city, Guangdong Province, China 518109

R&D base: Floor 4, Building 4, Nanshan Yungu Phase LI, Taoyuan Community, Xili Street, Nanshan District, Shenzhen

Tel: +86-755 2328 4603

Addresses and phone number also have been listed at www.etulinktechnology.com.

Please e-mail us at sales@etulinktechnology.com or call us for assistance.