

EAQPY-xx-1

100Gbps QSFP28 to QSFP28 Active Optical Cables

PRODUCT FEATURES

- Full duplex 4 channel 850nm parallel active optical cable
- Up to 27.95Gbps Data rate per channel
- Maximum link length of 150m links on OM3 multimode fiber
- High Reliability 850nm VCSEL technology
- Electrically hot-pluggable
- Case operating temperature range:0°C to 70°C
- Power dissipation < 2.5 W per cable end

APPLICATIONS

- 100G Ethernet
- Infiniband QDR
- Fiber channel
- HPC Interconnections

STANDARD

- Compliant to QSFP28 MSA
- RoHS Compliant.

DESCRIPTIONS

The ETU-LINK QSFP28 active optic cables are a high performance, low power consumption long reach interconnect solution supporting 100G Ethernet or Infini Band QDR/DDR/SDR,12.5G/10G/8G/4G/2G fiber channel ,PCIe and SAS. It is compliant with the QSFP MSA and IEEE P802.3ba. QSFP AOC is an assembly of 4 full-duplex lanes, where each lane is capable of transmitting data at rates up to 25.78125Gb/s, providing an aggregated rate of 104Gb/s. ETU-LINK QSFP28 AOC is one kind of parallel transceiver which provide sin creased port density and total system cost savings.

Module Block Diagram

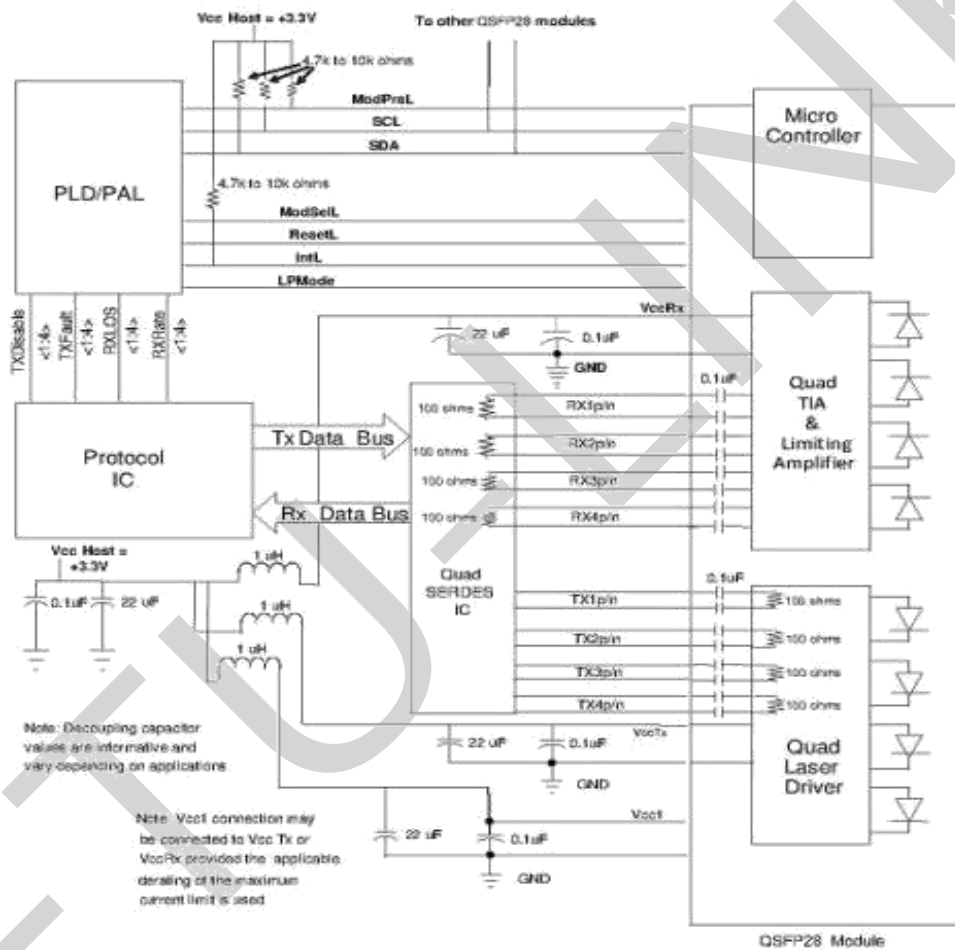

Ordering Information

Part No.	Description
EAQPY-xx-1-OM3	100Gbps QSFP28 to QSFP28 Active Optical Cables (AOC) OM3 0~70m

Notes:

- where "x" denotes cable length in meters. Examples are as follows:

2. x = 1 for 1m, xx=10 for 10m

Absolute Maximum Ratings

Parameter	Symbol	Min.	Typ.	Max.	Unit	Note
Storage Temperature	Ts	-40	-	85	°C	
Relative Humidity	RH	5	-	95	%	
Power Supply Voltage	VCC	-0.3	-	4	V	
Signal Input Voltage		Vcc-0.3	-	Vcc+0.3	V	

Recommended Operating Conditions

Parameter	Symbol	Min.	Typ.	Max.	Unit	Note
Case Operating Temperature	Tcase	0	-	70	°C	Without air flow
Power Supply Voltage	VCC	3.14	3.3	3.46	V	
Power Supply Current	ICC	-		750	mA	per cable end
Data Rate	BR		25.78125		Gbps	Each channel

General Product Characteristics

Parameter	Value	Unit	Notes
Module Form Factor	QSFP28		
Number of Lanes	4 Tx /Rx		
Maximum Aggregate Data Rate	111.8	Gb/s	
Maximum Data Rate per Lane	27.952	Gb/s	
Standard Cable Lengths	3, 5, 7, 10	meters	Other lengths, please contact sales
Protocols Supported	Typical applications include Infiniband, Fiber Channel, 100G Ethernet		
Electrical Interface and Pin-out	38-pin edge connector		Pin-out as defined by the QSFP28 MSA
Standard Optical Cable Type	Multimode ribbon fiber cable assembly, riser-rated		
Maximum Power Consumption per End	2.5	W	
Management Interface	Serial, I2C-based, 400 kHz maximum frequency		As defined by the QSFP28 MSA

Note:

1. 100G Ethernet & 100G BASE-SR4 and ITU-T OTU4 has different register setting, not auto-Negotiation

High-speed Electrical Characteristics per Lane

Parameter-Inputs	Symbol	Min	Typ	Max	Unit	NOTE
Input electrical specifications (per Lane)						
Differential Voltage pk-pk				900	mV	
Common Mode Noise RMS				17.5	mV	
Differential Termination Resistance Mismatch				10	%	
Differential Return Loss	SDD22	Per OIF CEI-28G-VSR and CAUI-4 requirements				
Common Mode to Differential conversion and Differential to Common Mode Conversion	SDC22, SCD22				dB	
Common Mode Return Loss	SCC22				dB	
Transition Time, 20 to 80%	Tr, Tf				10	
Common Mode Voltage	Vcm	-0.3		2.8	V	
Eye Width at 1E-15 probability	EW15	0.46			UI	
Eye Height at 1E-15 probability	EH15	94			mV	
Output electrical specifications (per Lane)						
Differential Voltage pk-pk				900	mV	
Common Mode Voltage	Vcm	-350		2850	mV	
Common Mode Noise RMS				17.5	mV	
Differential Termination Resistance Mismatch				10	%	
Differential Return Loss	SDD22	Per OIF CEI-28G-VSR and CAUI-4 requirements				
Common Mode to Differential conversion and Differential to Common Mode Conversion	SDC22, SCD22				dB	
Common Mode Return Loss	SCC22				dB	
Output Rise and Fall time (20% to 80%)	tRH, tFH				9.5	
Vertical Eye Closure	VEC			5.5	dB	
Eye Width at 1E-15 probability	EW15	0.57			UI	

Pin Diagram



Pin Definitions

Pin	Symbol	Name/Description	NOTE
1	GND	Transmitter Ground (Common with Receiver Ground)	1
2	Tx2n	Transmitter Inverted Data Input	
3	Tx2p	Transmitter Non-Inverted Data output	
4	GND	Transmitter Ground (Common with Receiver Ground)	1
5	Tx4n	Transmitter Inverted Data Input	
6	Tx4p	Transmitter Non-Inverted Data output	
7	GND	Transmitter Ground (Common with Receiver Ground)	1
8	ModSelL	Module Select	
9	ResetL	Module Reset	
10	VccRx	3.3V Power Supply Receiver	2
11	SCL	2-Wire serial Interface Clock	
12	SDA	2-Wire serial Interface Data	
13	GND	Transmitter Ground (Common with Receiver Ground)	
14	Rx3p	Receiver Non-Inverted Data Output	

15	Rx3n	Receiver Inverted Data Output	
16	GND	Transmitter Ground (Common with Receiver Ground)	1
17	Rx1p	Receiver Non-Inverted Data Output	
18	Rx1n	Receiver Inverted Data Output	
19	GND	Transmitter Ground (Common with Receiver Ground)	1
20	GND	Transmitter Ground (Common with Receiver Ground)	1
21	Rx2n	Receiver Inverted Data Output	
22	Rx2p	Receiver Non-Inverted Data Output	
23	GND	Transmitter Ground (Common with Receiver Ground)	1
24	Rx4n	Receiver Inverted Data Output	1
25	Rx4p	Receiver Non-Inverted Data Output	
26	GND	Transmitter Ground (Common with Receiver Ground)	1
27	ModPrsl	Module Present	
28	IntL	Interrupt	
29	VccTx	3.3V power supply transmitter	2
30	Vcc1	3.3V power supply	2
31	LPMODE	Low Power Mode , not connect	
32	GND	Transmitter Ground (Common with Receiver Ground)	1
33	Tx3p	Transmitter Non-Inverted Data Input	
34	Tx3n	Transmitter Inverted Data Output	
35	GND	Transmitter Ground (Common with Receiver Ground)	1
36	Tx1p	Transmitter Non-Inverted Data Input	
37	Tx1n	Transmitter Inverted Data Output	
38	GND	Transmitter Ground (Common with Receiver Ground)	1

Notes:

1. GND is the symbol for signal and supply (power) common for QSFP+ modules. All are common within the QSFP+ module and all module voltages are referenced to this potential unless otherwise noted. Connect these directly to the host board signal common ground plane.
2. VccRx, Vcc1 and VccTx are the receiving and transmission power suppliers and shall be applied concurrently. Recommended host board power supply filtering is shown below. Vcc Rx, Vcc1 and Vcc Tx may be internally connected within the QSFP28 transceiver module in any combination. The connector pins are each rated for a maximum current of 500mA.

Recommended Interface Circuit

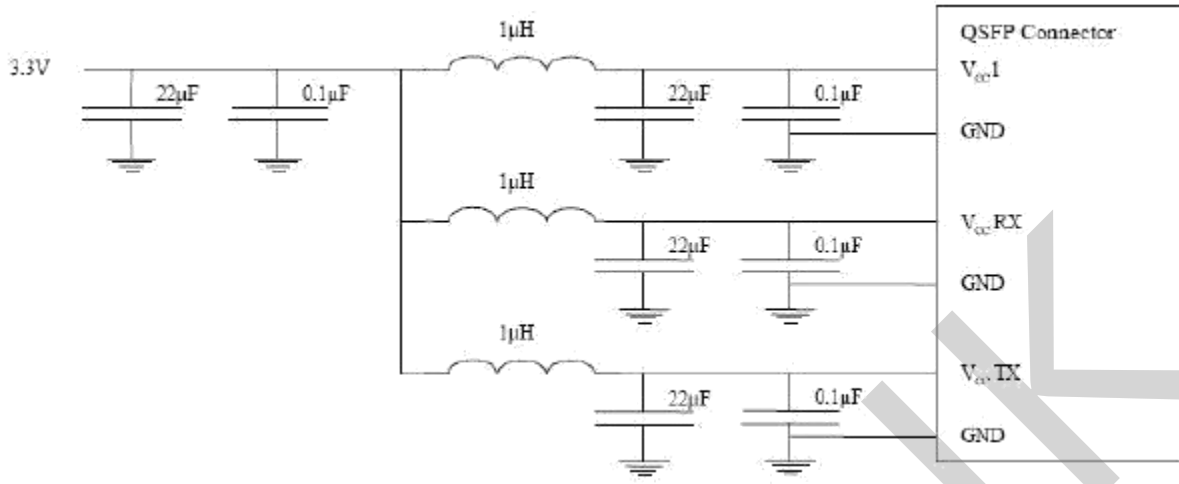

Mechanical Diagram

Unit: mm

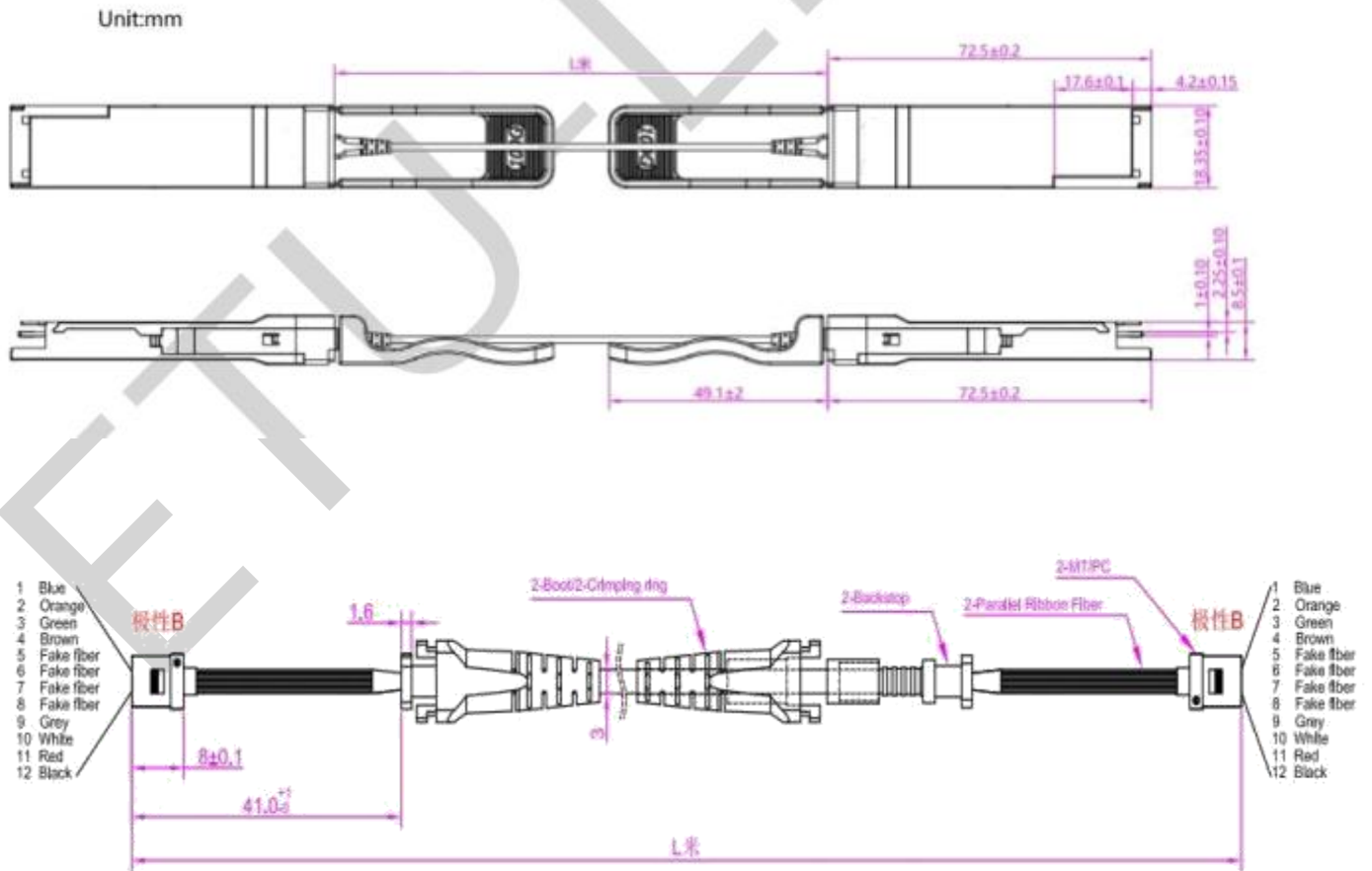

Revision History

Version No.	Date	Description
1.0	May 18, 2018	Preliminary datasheet
2.0	Spe 12,2025	Product upgrades

Company: ETU-Link Technology Co., LTD

Production base: Right side of 3rd floor, No. 102 building, Longguan expressway, Dalang street, Longhua District, Shenzhen city, Guangdong Province, China 518109

R&D base: Floor 4, Building 4, Nanshan Yungu Phase LI, Taoyuan Community, Xili Street, Nanshan District, Shenzhen

Tel: +86-755 2328 4603

Addresses and phone number also have been listed at www.etulinktechnology.com.

Please e-mail us at sales@etulinktechnology.com or call us for assistance.