

EB93(39)2X-40D(I)

25Gb/s SFP28 BIDI 40km DDM Transceiver

PRODUCT FEATURES

- Support data rate up to 25.78125Gb/s
- Hot-Pluggable SFP Footprint and Single LC Connector
- Up to 40km reach for G.652 SMF
- EML TX and Integrated APD RX
- Temperature Range:
 - Commercial: 0°C ~70°C
 - Industrial: -40°C ~85°C
- Power consumption
 - Commercial: 1.5W
 - Industrial: 1.8W
- RoHS 6 compliance
- Compliant to IEEE 802.3cc, SFF-8472 and SFF-8419
- Complies with EU Directive 2015/863/EU

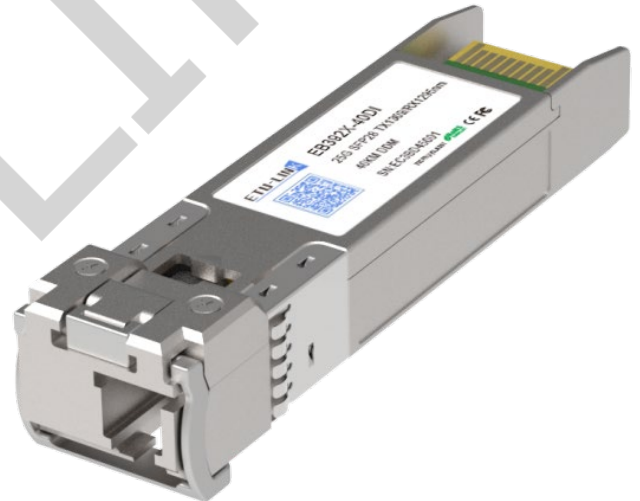

APPLICATIONS

- 25G Ethernet
- CPRI option 10

DESCRIPTIONS

The EB93(39)2X-40D(I) series single mode transceiver is small form factor pluggable module for duplex optical data communications. The EB93(39)2X-40D(I) module is designed for single mode fiber and operates at a nominal wavelength of 1295.56nm or 1309.14nm; the transmitter section uses a multiple quantum well EML, which is class 1 laser compliant according to International Safety Standard IEC-60825.

The SFP28 40km module electrical interface is compliant to SFI electrical specifications. The transmitter input and receiver output impedance is 100 Ohms differential. Data lines are internally AC coupled. The module provides differential termination and reduce differential to common mode conversion for quality signal termination and low EMI.

Module Block Diagram

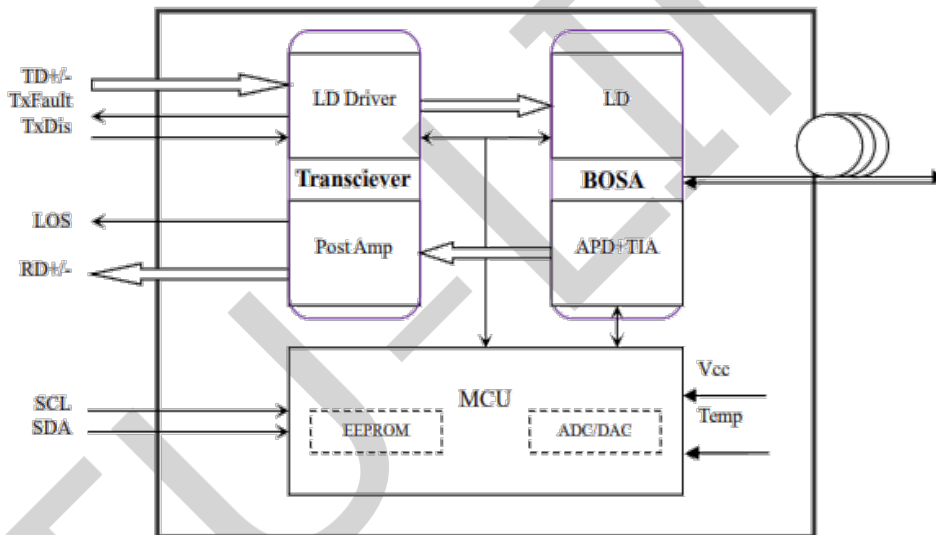

Ordering Information

Part No.	Data Rate(optical)	Laser	Fiber Type	Distance	Optical Interface	Temp	DDMI	Latch Color
EB932X-40D	25.78Gbps	EML	SMF	40km	LC	0~70℃	Y	Purple
EB392X-40D	25.78Gbps	EML	SMF	40km	LC	0~70℃	Y	Yellow
EB932X-40DI	25.78Gbps	EML	SMF	40km	LC	-40~85℃	Y	Purple
EB392X-40DI	25.78Gbps	EML	SMF	40km	LC	-40~85℃	Y	Yellow

Absolute Maximum Ratings

Parameter	Symbol	Min.	Typical	Max.	Unit	Notes
Storage Temperature	T _{stg}	-40		+85	℃	

Optical Communications Products Alliance

Case Operating Temperature(Commercial)	T_o	0		70	°C	
Case Operating Temperature (Industrial)	T_o	-40		85	°C	
Relative Humidity - Storage	R_{HS}	5		95	%	
Relative Humidity - Operating	R_{HO}	5		85	%	
DC Supply Voltage	V_{CC}	0		3.6	V	

Recommended Operating Conditions

Parameter	Symbol	Min.	Typical	Max.	Unit	Notes
Case Operating Temperature	T_{op}	0	-	70	°C	Commercial
		-40		85		Industrial
Power Supply Voltage	V_{CC}	3.13	3.3	3.47	V	
Transmission Distance	TD	-	-	40	km	Over SMF

Electrical Characteristics

High-Speed Signal: Compliant to CEI-25G-VSR

Low-Speed Signal: Compliant to SFF-8431

Parameter	Symbol	Min.	Typical	Max.	Unit	Notes	
Supply Voltage	V_{CC}	3.135		3.465	V		
Supply Current	I_{CC}			450	mA	Commercial	
				540		Industrial	
Power Consumption	P			1.5	W	Commercial	
				1.8		Industrial	
Transmitter (Module Input)							
Differential Input Resistance	R_{Rdin}	90	100	110	Ω		
Input Differential Voltage	R_{Vdiff}	-	-	900	mVpp		
Tx_Disable	Normal Operation	V_{IL}	-0.3	-	0.8	V	
	Laser Disable	V_{IH}	2.0	-	$V_{CC}+0.3$	V	
Receiver (Module Output)							
Differential Resistance	T_{Rd}	90	100	110	Ohm		
Output Differential Voltage	T_{Vdiff}	-	-	900	mVpp		
Differential Termination Resistance Mismatch	T_{Rdm}	-	-	10	%		
Rx los	Normal Operation	V_{OL}	-0.3	-	0.4	V	
	Loss Signal	V_{OH}	2		V_{CCHOST}	V	

Optical and Characteristics

Parameter	Symbol	Min.	Typical	Max.	Unit	Notes
Transmitter						
Average Output Power	POUT	2		7	dBm	1
Average Output Power(Laser Off)	POFF			-30	dBm	
Wavelength	λ	1294.53	1295.56	1296.59	nm	EB932X-40D(I)
		1308.09	1309.14	1310.19		EB392X-40D(I)
Spectrum Bandwidth @ -20dB	$\Delta\lambda$			1	nm	
Side mode suppression ratio(SMSR)	SMSR	30			dB	
Extinction ratio	ER	8			dB	
RIN ₂₀ OMA	RIN			-128	dB/Hz	
Transmitter and dispersion penalty (TDP)				2.7	dB	
Receiver						
Wavelength	λ	1308.09	1309.14	1310.19	nm	EB932X-40D(I)
		1294.53	1295.56	1296.59		EB392X-40D(I)
Received Sensitivity	P _{IN}			-19	dBm	40km NO FEC
Received Sensitivity	P _{IN}			-21	dBm	40km with FEC
Optical Power Overload	P _{IN} (SAT)	-4			dBm	
Damage threshold		3			dBm	1
Rx_LOS of Signal Assert	P _A	-40			dBm	
Rx_LOS of Signal De-assert	P _D			-23	dBm	
Rx_LOS of Signal Hysteresis	PHy	0.5		5	dB	
Optical Return Loss Tolerance	ORLT	20			dB	

Notes:

- The receiver shall be able to tolerate, without damage, continuous exposure to an optical input signal having this average power level. The receiver does not have to operate correctly at this input power

Digital Diagnostics

Parameter	Range	Accuracy	Unit	Calibration
Temperature	-40 to 85	±3	°C	Internal
Voltage	3.13-3.47	±3%	V	Internal
Tx Bias Current	0 to 100	±10%	mA	Internal
Tx Output Power	2 to 7	±3	dB	Internal
Rx Input Power	-22 to -4	±3	dB	Internal

Communication Interface Timing Characteristics

Parameter	Symbol	Min.	Typical	Max.	Unit	Notes
TX_Disable Assert Time	t _{off}			100	us	
TX_Disable Negate Time	t _{on}			2	ms	
Time to Initialize Include Reset of	t _{int}			300	ms	

TX_FAULT						
TX_FAULT from Fault to Assertion	t_fault			100	us	
TX_Disable Time to Start Reset	t_reset	10			us	
Receiver Loss of Signal Assert Time	T _{A,RX_LOS}			100	us	
Receiver Loss of Signal Deassert Time	T _{d,RX_LOS}			100	us	
Rate-Select Chage Time	t_ratesel			10	us	

Pin Diagram

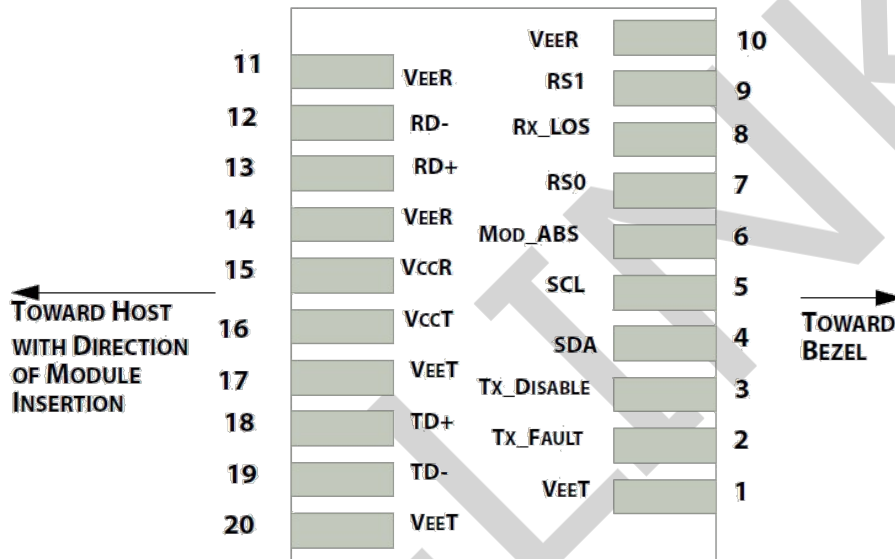

Pin Definitions

PIN #	Name	Function	Notes
1	VeeT	Module transmitter ground	1
2	Tx Fault	Module transmitter fault	2
3	Tx Disable	Transmitter Disable; Turns off transmitter laser output	3
4	SDL	2 wire serial interface data input/output (SDA)	4
5	SCL	2 wire serial interface clock input (SCL)	4
6	MOD-ABS	Module Absent, connect to VeeR or VeeT in the module	4
7	RS0	Rate select0, optionally control SFP+ receiver. When high, input data rate >4.5Gb/ s; when low, input data rate <=4.5Gb/s	5
8	LOS	Receiver Loss of Signal Indication	6
9	RS1	Rate select0, optionally control SFP+ transmitter. When high, input data rate >4.5Gb/s; when low, input data rate <=4.5Gb/s	1
10	VeeR	Module receiver ground	1
11	VeeR	Module receiver ground	1

12	RD-	Receiver inverted data output	
13	RD+	Receiver non-inverted data output	
14	VeeR	Module receiver ground	1
15	VccR	Module receiver 3.3V supply	
16	VccT	Module transmitter 3.3V supply	
17	VeeT	Module transmitter ground	1
18	TD+	Transmitter inverted data output	
19	TD-	Transmitter non-inverted data output	
20	VeeT	Module transmitter ground	1

Notes:

1. Circuit ground is internally isolated from chassis ground
2. Tx FAULT is an open collector/drain output, which should be pulled up with a 4.7k – 10k Ohms resistor on the host board if intended for use. Pull up voltage should be between 2.0V to Vcc + 0.3V. A high output indicates a transmitter fault caused by either the TX bias current or the TX output power exceeding the preset alarm thresholds. A low output indicates normal operation. In the low state, the output is pulled to <0.8V.
3. Laser output disabled on Tx DIS >2.0V or open, enabled on Tx DIS <0.8V.
4. Should be pulled up with 4.7kΩ- 10kΩ host board to a voltage between 2.0V and 3.6V. MOD_ABS pulls line low to indicate module is plugged in.
5. Internally pulled down per SFF-8431 Rev 4.1.
6. LOS is open collector output. It should be pulled up with 4.7kΩ – 10kΩ on host board to a voltage between 2.0V and 3.6V. Logic 0 indicates normal operation; logic 1 indicates loss of signal.

Recommended Interface Circuit

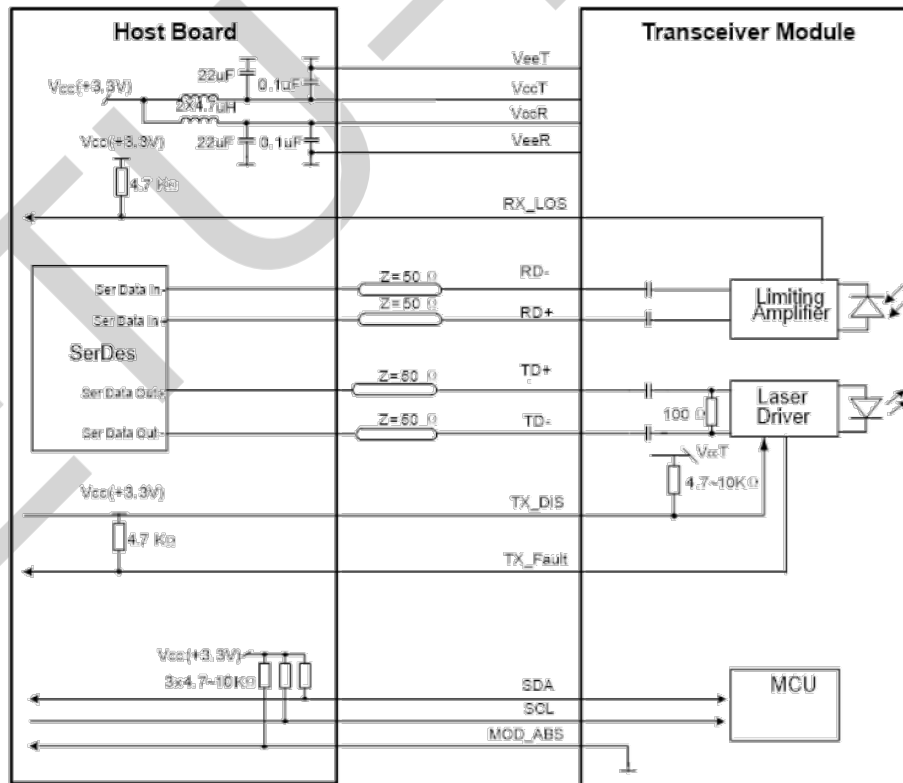

Mechanical Diagram

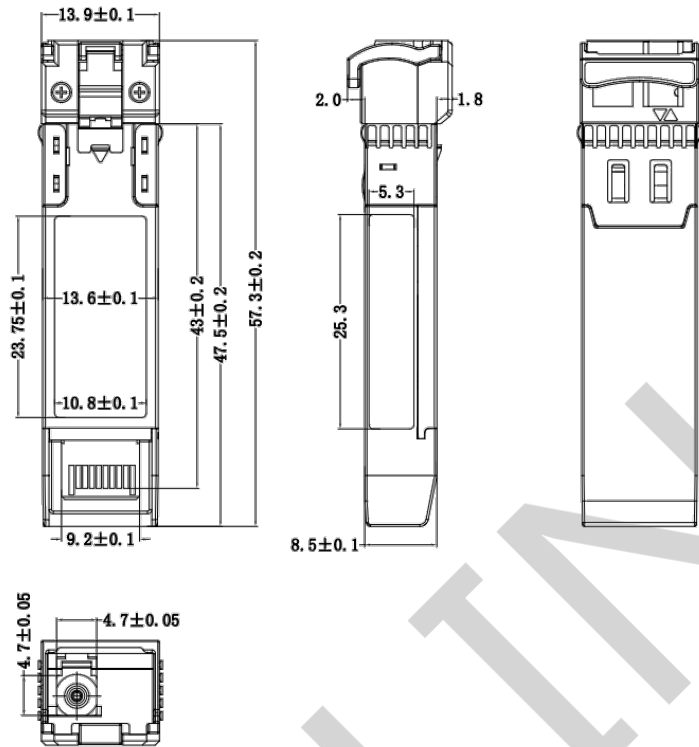

Revision History

Version No.	Date	Description
1.0	February 18, 2023	Preliminary datasheet
2.0	Aug 21, 2024	Format change

Company: ETU-Link Technology Co., LTD

Production base: Right side of 3rd floor, No. 102 building, Longguan expressway, Dalang street, Longhua District, Shenzhen city, Guangdong Province, China 518109

R&D base: Floor 4, Building 4, Nanshan Yungu Phase LI, Taoyuan Community, Xili Street, Nanshan District, Shenzhen

Tel: +86-755 2328 4603

Addresses and phone number also have been listed at www.etulinktechnology.com.

Please e-mail us at sales@etulinktechnology.com or call us for assistance.