

ETU-LINK

Optical Communication System

QSFP+ Series

QSFP+

EQxx4X-3LCD2

40Gbps QSFP+ Transceiver, Single Mode, 2km Reach

- 4 CWDM lanes MUX/DEMUX design
- Transmission data rate up to 11.3Gbps per channel
- SMF LC duplex connector
- Hot Pluggable QSFP+ form factor
- Up to 2km SMF or 150m om4 MMF transmission
- Compatible with RoHS
- Single +3.3V power supply
- Real Time Digital Diagnostic Monitoring
- Operating case temperature: 0 to +70°C



Applications

- 40GBASE-LX4 Ethernet
- Infiniband QDR and DDR interconnects
- Client-side 40G Datacom connections

Description

The transceivers are high performance, cost effective modules supporting data rate of 40Gbps and 2km transmission distance with SMF or 100m om4 MMF.

The transceiver consists of three sections: 4 inputs channels (ch) of 10Gb/s electrical data to 4 CWDM optical signals, and multiplexes them into a single channel for 40Gb/s optical transmission; on the receiver side, the module optically de-multiplexes a 40Gb/s input into 4 CWDM channels signals, and converts them

to 4 channel output electrical data; and MCU control unit. All modules satisfy class I laser safety requirements.

The transceivers are compatible with 40GBASE-LX4 of IEEE802.3ba standard and SFF-8436 specification.

Absolute Maximum Ratings

Parameter	Symbol	Min	Max	Unit
Supply Voltage	Vcc	-0.5	3.6	V
Storage Temperature	Ts	-40	+85	°C
Operating Humidity	-	5	85	%

Recommended Operating Conditions

Parameter	Symbol	Min	Typical	Max	Unit
Operating Case Temperature	Tc	0		+70	°C
Power Supply Voltage	Vcc	3.135	3.30	3.465	V
Power Dissipation	Pm			2.5	W
Data Rate			10.3125	11.3	Gbps

Optical and Electrical Characteristics

Parameter	Symbol	Min	Typical	Max	Unit	Notes
Transmitter						
Centre Wavelength	L0	1264.5	1271	1277.5	nm	
	L1	1284.5	1291	1297.5	nm	
	L2	1304.5	1311	1317.5	nm	
	L3	1324.5	1331	1337.5	nm	
-20dB Spectral Width	$\Delta\lambda$			1	nm	
Side-mode Suppression Ratio	SMSR	30	-		dB	
Total Average Launch Power	P _T			8.3	dBm	
Average launch power, each lane (for SMF)	P _{out}	-7		2.3	dBm	
Average launch power, each lane (for MMF)	P _{out}	-5		3.5	dBm	
OMA, each Lane (for SMF)	P _{oma}	-6		3.5	dBm	
OMA, each Lane (for MMF)	P _{oma}	-4		4.5	dBm	

Extinction Ratio	ER	3.5			dB	
Average launch power of OFF transmitter,each lane	P _{off}			-30	dBm	
Relative Intensity Noise	R _{in}			-128	dB/Hz	12dB reflection
Transmitter Reflectance	R _T			-12	dB	
Data Input Swing Differential	V _{IN}	190		700	mV	
Input Differential Impedance	Z _{IN}	90	100	110	Ω	
Receiver						
Centre Wavelength	L0	1264.5	1271	1277.5	nm	
	L1	1284.5	1291	1297.5	nm	
	L2	1304.5	1311	1317.5	nm	
	L3	1324.5	1331	1337.5	nm	
Damage threshold	THd	3.3			dBm	
Average power at receiver input,each lane(for SMF)		-11.5		2.3	dBm	
Average power at receiver input,each lane(for MMF)		-7		3.5	dBm	
Receive Sensitivity (OMA), each Lane (for SMF)				-11.5	dBm	
Receive Sensitivity (OMA), each Lane (for MMF)				-10.5	dBm	
LOS De-Assert	LOS _D			-15	dBm	
LOS Assert	LOS _A	-30			dBm	
LOS Hysteresis		0.5			dB	
Receive Electrical 3 dB upper Cutoff Frequency, each Lane	F _c			11.3	GHz	

Digital Diagnostic Memory Map

The transceivers provide serial ID memory contents and diagnostic information about the present operating conditions by the 2-wire serial interface (SCL, SDA).

The digital diagnostic memory map specific data field defines as following.

2-Wire Serial Address: 1010000x

0	ID and status	(3 Bytes)
2	Interrupt Flags	(19 Bytes)
21	Module Monitors	(12 Bytes)
33	Channel Monitors	(48 Bytes)
81	Reserved	(4 Bytes)
85	Control	(12 Bytes)
97	Reserved	(2 Bytes)
99	Free Side Device and Channel Mask	(7 Bytes)
106	Reserved	(1 Bytes)
107	Free Side Device Properties	(4 Bytes)
111	Reserved	(7 Bytes)
118	Password Change Entry Area (Optional)	(4 Bytes)
122	Password Entry Area (Optional)	(4 Bytes)
126	Page Select Byte	(1 Bytes)
127		

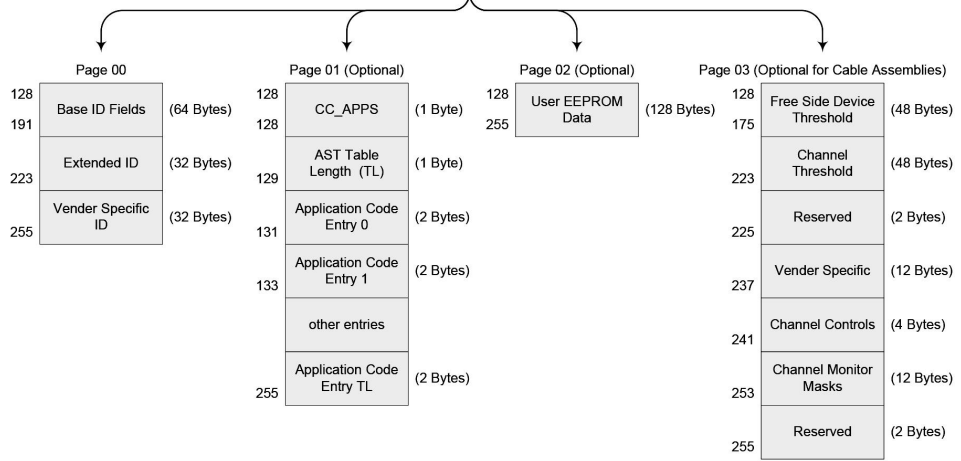

Pin Descriptions

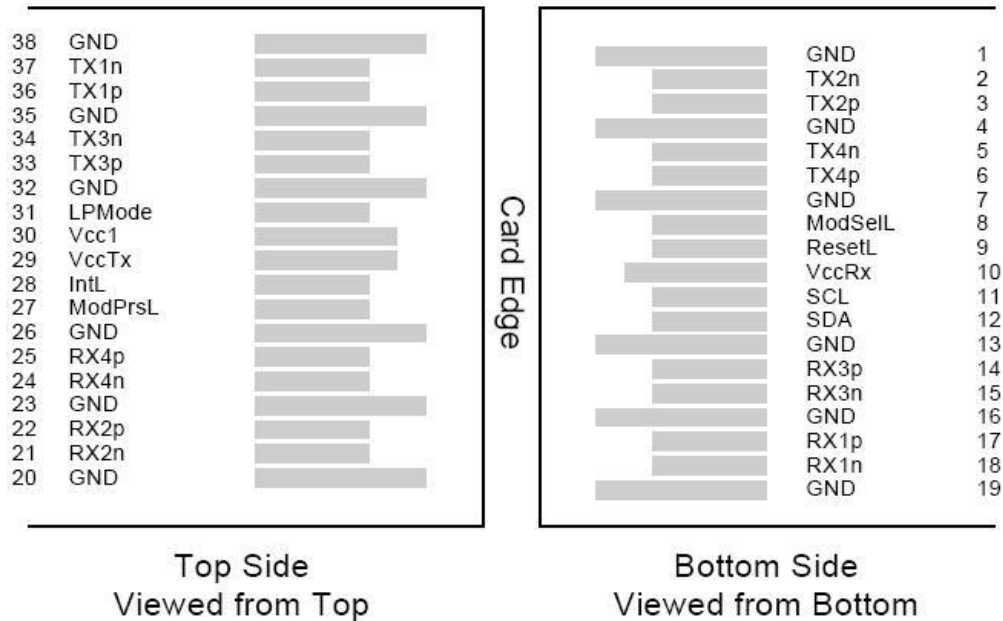

PIN	Logic	Symbol	Name/Description	Note
1		GND	Ground	1
2	CML-I	Tx2n	Transmitter Inverted Data Input	
3	CML-I	Tx2p	Transmitter Non-Inverted Data output	
4		GND	Ground	1
5	CML-I	Tx4n	Transmitter Inverted Data Input	
6	CML-I	Tx4p	Transmitter Non-Inverted Data output	
7		GND	Ground	1
8	LVTLL-I	ModSelL	Module Select	
9	LVTLL-I	ResetL	Module Reset	
10		VccRx	+ 3.3V Power Supply Receiver	2
11	LVC MOS-I/O	SCL	2-Wire Serial Interface Clock	
12	LVC MOS-I/O	SDA	2-Wire Serial Interface Data	
13		GND	Ground	
14	CML-O	Rx3p	Receiver Non-Inverted Data Output	
15	CML-O	Rx3n	Receiver Inverted Data Output	
16		GND	Ground	1
17	CML-O	Rx1p	Receiver Non-Inverted Data Output	
18	CML-O	Rx1n	Receiver Inverted Data Output	
19		GND	Ground	1
20		GND	Ground	1
21	CML-O	Rx2n	Receiver Inverted Data Output	

22	CML-O	Rx2p	Receiver Non-Inverted Data Output	
23		GND	Ground	1
24	CML-O	Rx4n	Receiver Inverted Data Output	1
25	CML-O	Rx4p	Receiver Non-Inverted Data Output	
26		GND	Ground	1
27	LVTTTL-O	ModPrsL	Module Present	
28	LVTTTL-O	IntL	Interrupt	
29		VccTx	+3.3 V Power Supply transmitter	2
30		Vcc1	+3.3 V Power Supply	2
31	LVTTTL-I	LPMoDe	Low Power Mode	
32		GND	Ground	1
33	CML-I	Tx3p	Transmitter Non-Inverted Data Input	
34	CML-I	Tx3n	Transmitter Inverted Data Output	
35		GND	Ground	1
36	CML-I	Tx1p	Transmitter Non-Inverted Data Input	
37	CML-I	Tx1n	Transmitter Inverted Data Output	
38		GND	Ground	1

Notes:

1. GND is the symbol for signal and supply (power) common for QSFP modules. All are common within the QSFP module and all module voltages are referenced to this potential unless otherwise noted. Connect these directly to the host board signal common ground plane.
2. VccRx, Vcc1 and VccTx are the receiver and transmitter power suppliers and shall be applied concurrently. Recommended host board power supply filtering is shown below. Vcc Rx, Vcc1 and Vcc Tx may be internally connected within the QSFP transceiver module in any combination. The connector pins are each rated for a maximum current of 500mA.

Mechanical Dimensions

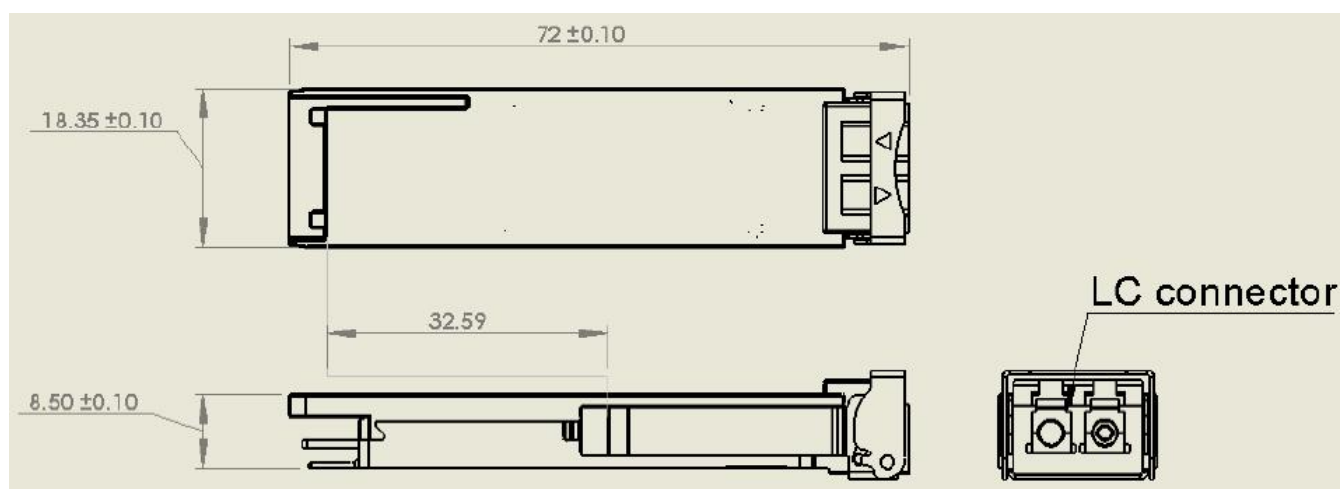

Compatibility Test

In order to ensure the product compatibility, our products will be tested on the switch before shipment. Our modules can be compatible with many mainstream brand switches, such as Cisco, Juniper, Extreme, Brocade, IBM, H3C, HP, Huawei, D-Link, Mikrotik, ZTE, TP-Link...

Our test equipment: VOLKTEK MEN-4110, HP 2530-8G, CRS226-24G-25+RM, Catalyst 2960G Series, Catalyst 3850 XS 10G SFP+, Catalyst 3750-E Series, HUAWEI S5700Series, H3C S3100V2 Series, Juniper-EX4200, etc.



Cisco Catalyst 3850



HUAWEI S5700



H3C S3100V2



HP J9264AR



Juniper EX 4200



Alcatel 6850E-U24X



Mikrotik CR5226-24G-25+RM



Cisco Catalyst 2960G



Volktek MEN-4110

Product Production Process

Quality Assurance

Continuous introduction of new equipment, produced by strict standards, strict quality inspection, to guarantee the high quality standard of each product.



**Standardized
Production Line**



**Professional
Welding**



Assembling



Aging Testing

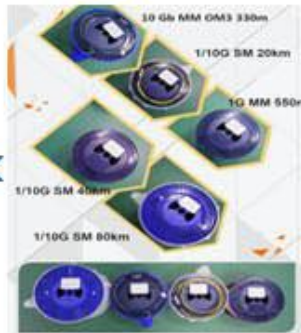

Distance Testing



Cleaning end face



Product Initial Test



Switch Testing



Product Final Test

Packaging

ETU-Link provides two kinds of packaging, 10pcs/Tray and individual package.



Company: ETU-Link Technology Co., LTD

Address: 4th Floor, C Building, JinBoLong Industrial Park, QingQuan Road, LongHua District, Shenzhen city, GuangDong

Tel: +86-755 2328 4603

Addresses and phone number also have been listed at www.etulinktechnology.com.

Please e-mail us at sales@etulinktechnology.com or call us for assistance.