

ESP3112-05D(I)

1.25Gbps SFP Optical Transceiver, 550M Reach

PRODUCT FEATURES

- **Data-rate 155M and 1.25Gbps operation**
- **155M 1310nm FP laser and PIN photo detector for 2KM transmission with MMF**
- **1.25G 1310nm FP laser and PIN photo detector for 550M transmission with MMF**
- **Compliant with SFP MSA and SFF-8472 with duplex LC receptacle**
- **Digital Diagnostic Monitoring:**
- **Internal Calibration or External Calibration**
- **Compatible with SONET OC-24-LR-1**
- **Compatible with RoHS**
- **+3.3V single power supply**
- **Operating case temperature:**
 - Standard: 0 to +70°C**
 - Extended: -20 to 85°C**
 - Industrial: -40 to +85°C**

APPLICATIONS

- **Gigabit Ethernet**
- **Fiber Channel**
- **Switch to Switch interface**
- **Switched backplane applications**
- **Router/Server interface**
- **Other optical transmission systems**

DESCRIPTIONS

The SFP transceivers are high performance, cost effective modules supporting data-rate of 155M and 2KM transmission distance with MMF.

The SFP transceivers are high performance, cost effective modules supporting data-rate of 1.25Gbps and 550M transmission distance with MMF

The transceiver consists of three sections: a FP laser transmitter, a PIN photodiode integrated with a trans-impedance preamplifier (TIA) and MCU control unit. All modules satisfy class I laser safety requirements.

The transceivers are compatible with SFP Multi-Source Agreement (MSA) and SFF-8472. For further information, please refer to SFP MSA.

Module Block Diagram

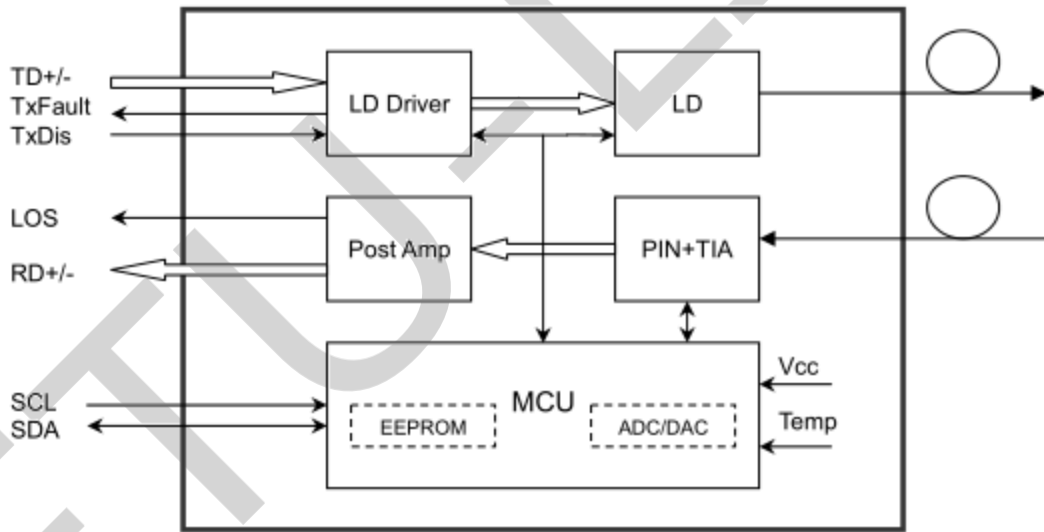

Ordering Information

Part No.	Data Rate(optical)	Laser	Fiber Type	Distance	Optical Interface	Temp	DDMI	Latch Color
ESP3112-05D	1.25Gbps	FP	MMF	550M	LC	0~70°C	Y	Black
ESP3112-05DE	1.25Gbps	FP	MMF	550M	LC	-20~85°C	Y	Black
ESP3112-05DI	1.25Gbps	FP	MMF	550M	LC	-40~85°C	Y	Black

Absolute Maximum Ratings

Parameter	Symbol	Min	Typ	Max	Unit	Ref.
Maximum Supply Voltage	V _{cc}	-0.5		4.7	V	
Storage Temperature	TS	-40		85	°C	
Case Operating Temperature	TOP	0		70	°C	Standard
Case Operating Temperature	TOP	-40		85	°C	Industrial

Recommended Operating Conditions

Parameter	Symbol	Min.	Typical	Max.	Unit	Notes
Case Operating Temperature	Top	0	-	70	°C	Commercial
		-40		85		Industrial
Power Supply Voltage	V _{cc}	3.13	3.3	3.47	V	
Transmission Distance	TD	-	-	550	km	Over SMF

Electrical Characteristics

Parameter	Symbol	Min	Typ	Max	Unit	Ref.
Supply Voltage	V _{cc}	3.15	3.3	3.6	V	
Supply Current	I _{cc}			303	mA	
Transmitter						
Input differential impedance	R _{in}		100		Ω	1
Single ended data input swing	V _{in,pp}	250		1200	mV	
Transmit Disable Voltage	V _D	V _{cc} -1.3		V _{cc}	V	
Transmit Enable Voltage	V _{EN}	V _{ee}		V _{ee} + 0.8	V	2
Transmit Disable Assert Time				10	us	
Receiver						
Single ended data output swing	V _{out,pp}	250		800	mV	3
Data output rise time	t _r		100	175	ps	4
Data output fall time	t _f		100	175	ps	4
LOS Fault	V _{LOS fault}	V _{cc} -0.5		V _{cc} HOST	V	5
LOS Normal	V _{LOS norm}	V _{ee}		V _{ee} +0.5	V	5
Power Supply Rejection	PSR	100			mV _{pp}	6

Notes:

1. Connected directly to TX data input pins. AC coupled thereafter.
2. Or open circuit.
3. Into 100 ohms differential termination.
4. 20 – 80 %
5. Loss of Signal is LVTTTL. Logic 0 indicates normal operation; logic 1 indicates no signal detected.
6. Receiver sensitivity is compliant with power supply sinusoidal modulation of 20 Hz to 1.5 MHz up to specified value applied through the recommended power supply filtering network.

Optical and Characteristics

Parameter	Symbol	Min	Typ	Max	Unit	Ref.
Transmitter						
Output Opt. Pwr (End of Life)	POUT	-9		-3.0	dBm	1
Optical Wavelength	λ	1270	1310	1360	nm	
Wavelength Temperature Dependence			0.08	0.125	nm/°C	
Spectral Width (-20dB)	σ			3.0	nm	
Optical Extinction Ratio	ER	10			dB	
Optical Rise/Fall Time	tr/ tf	30			ps	
RIN	RIN		100	160	dB/Hz	
Transmitter Jitter (peak to peak)				-120	ps	
Receiver						
Average Rx Sensitivity @ Gigabit Ethernet	RSENS3			-20.0	dBm	2
Maximum Input Power	PMAX	-3.0			dBm	
Optical Center Wavelength	λ_C	1260	1310	1620	nm	
LOS De -Assert	LOSD			-22	dBm	
LOS Assert	LOSA	-40			dBm	
LOS Hysteresis			1.0		dB	
Receiver Jitter Generation @1.25Gbps				160	ps	3

Notes:

1. Class 1 Laser Safety per FDA/CDRH and IEC-825-1 regulations.
2. with worst-case extinction ratio. Measured with a PRBS 2^7-1 test pattern, @1.25Gb/s, BER10^{-12}
- 3 Jitter added by receiver (peak to peak). Measured at -18.0dBm average Rx sensitivity, PRBS 2^7-1 test pattern.

Digital Diagnostics

Parameter	Range	Accuracy	Unit	Calibration
Temperature	-40 to 85	± 3	°C	Internal
Voltage	0 to Vcc	$\pm 3\%$	V	Internal
Tx Bias Current	0 to 100	$\pm 10\%$	mA	Internal
Tx Output Power	-9 to -3	± 3	dB	Internal
Rx Input Power	-20 to -3	± 3	dB	Internal

Pin Diagram

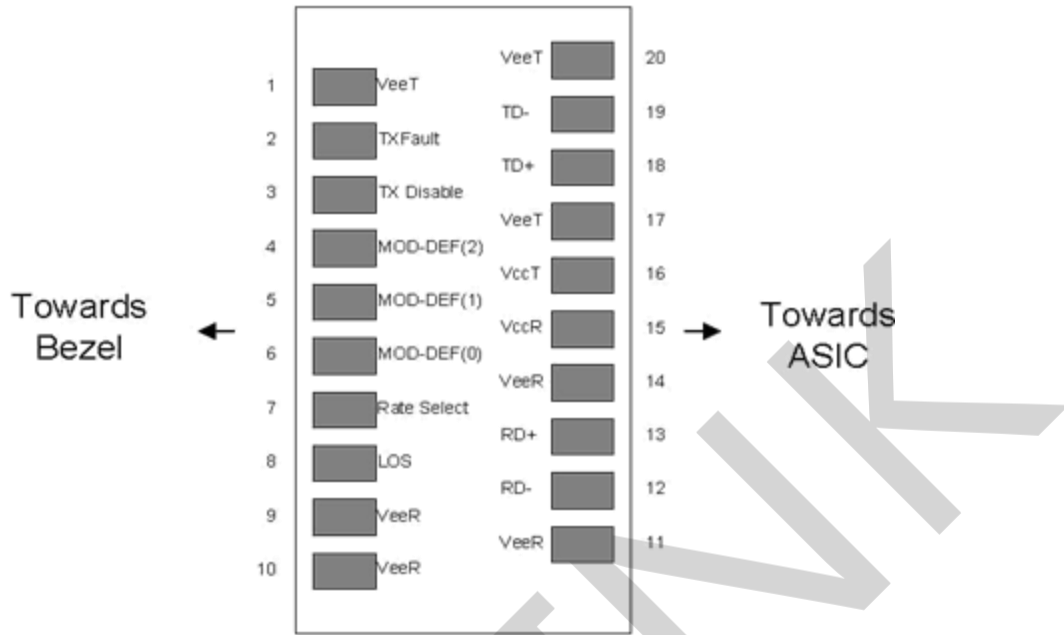

Pin Definitions

Pin	Symbol	Name/Description	Ref.
1	V_{EET}	Transmitter Ground (Common with Receiver Ground)	1
2	T_{FAULT}	Transmitter Fault.	2
3	T_{DIS}	Transmitter Disable. Laser output disabled on high or open.	3
4	MOD_DEF(2)	Module Definition 2. Data line for Serial ID.	4
5	MOD_DEF(1)	Module Definition 1. Clock line for Serial ID.	4
6	MOD_DEF(0)	Module Definition 0. Grounded within the module.	4
7	Rate Select	No connection required	
8	LOS	Loss of Signal indication. Logic 0 indicates normal operation.	5
9	V_{EER}	Receiver Ground (Common with Transmitter Ground)	1
10	V_{EER}	Receiver Ground (Common with Transmitter Ground)	1
11	V_{EER}	Receiver Ground (Common with Transmitter Ground)	1
12	RD-	Receiver Inverted DATA out. AC Coupled	
13	RD+	Receiver Non-inverted DATA out. AC Coupled	
14	V_{EER}	Receiver Ground (Common with Transmitter Ground)	1
15	V_{CCR}	Receiver Power Supply	
16	V_{CCT}	Transmitter Power Supply	
17	V_{EET}	Transmitter Ground (Common with Receiver Ground)	1
18	TD+	Transmitter Non-Inverted DATA in. AC Coupled.	
19	TD-	Transmitter Inverted DATA in. AC Coupled.	
20	V_{EET}	Transmitter Ground (Common with Receiver Ground)	1

Notes:

1. Circuit ground is internally isolated from chassis ground.
2. T_{FAULT} is an open collector/drain output, which should be pulled up with a 4.7k – 10k Ohms resistor on the host board if intended for use. Pull up voltage should be between 2.0V to $V_{cc} + 0.3V$. A high output indicates a transmitter fault caused by either the TX bias current or the TX output power exceeding the preset alarm thresholds. A low output indicates normal operation. In the low state, the output is pulled to <0.8V.
3. Laser output disabled on $T_{DIS} > 2.0V$ or open, enabled on $T_{DIS} < 0.8V$.
4. Should be pulled up with 4.7k- 10kohms on host board to a voltage between 2.0V and 3.6V. MOD_DEF(0) pulls line low to indicate module is plugged in.
5. LOS is open collector output. Should be pulled up with 4.7k – 10 kohms on host board to a voltage between 2.0V and 3.6V. Logic 0 indicates normal operation; logic 1 indicates loss of signal.

Recommended Interface Circuit

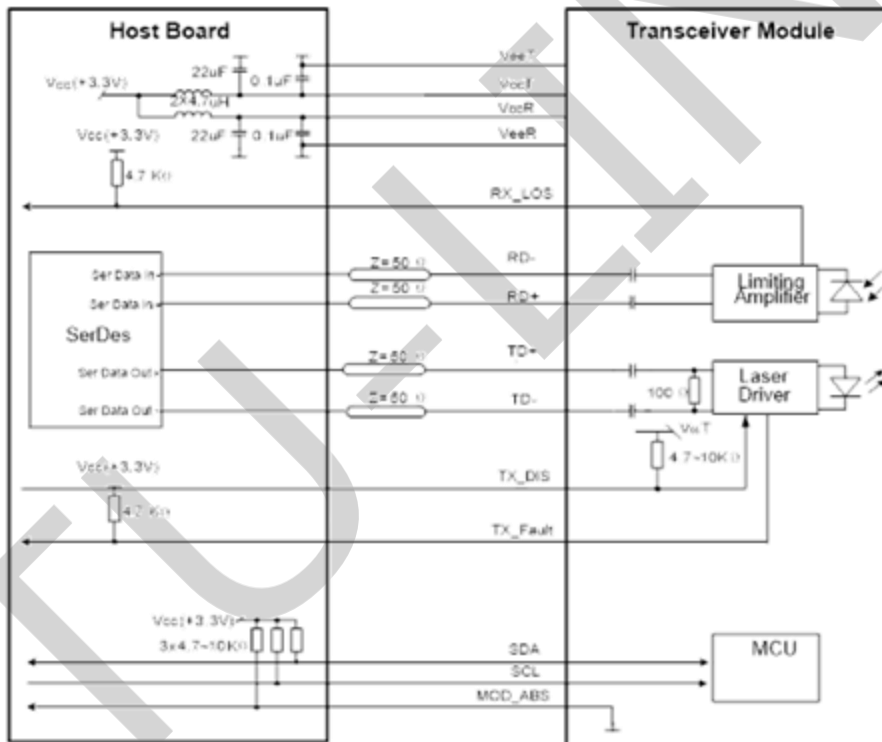

Mechanical Diagram

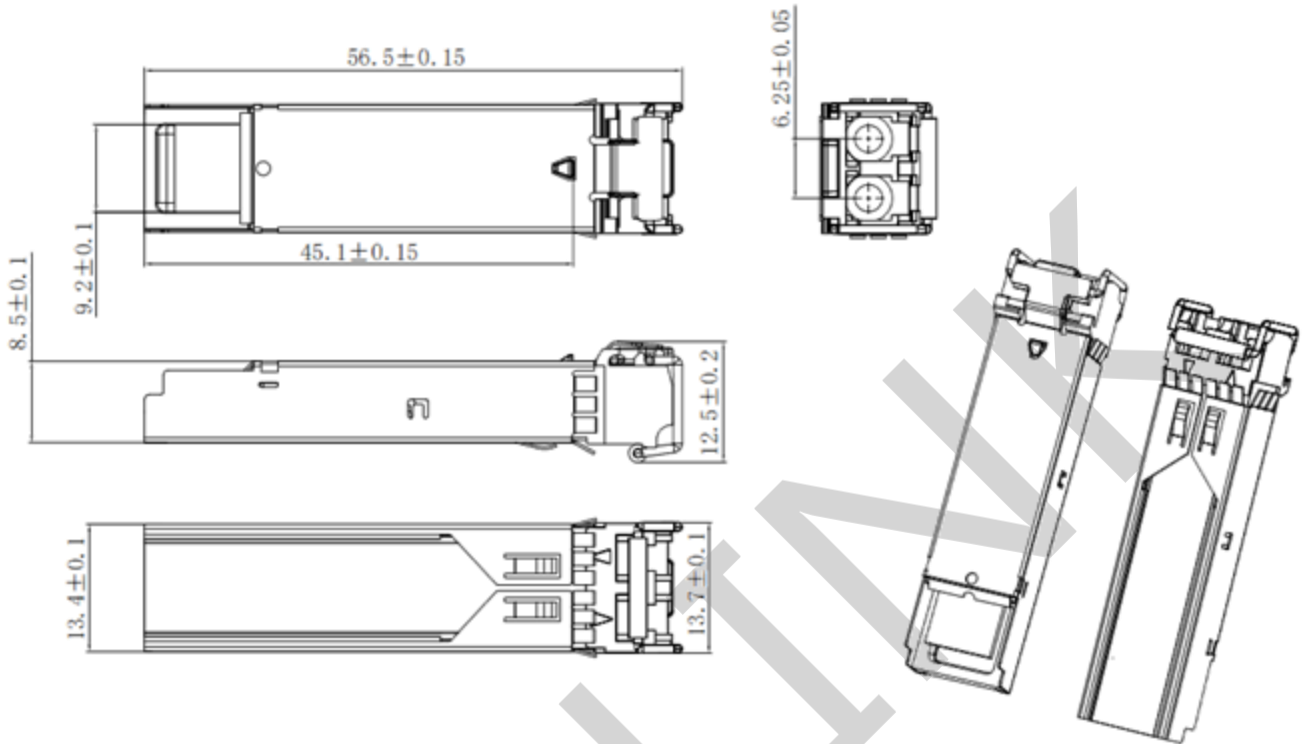

Revision History

Version No.	Date	Description
1.0	February 19, 2016	Preliminary datasheet
2.0	September 24, 2023	Product upgrades
3.0	July 21, 2024	Format change

Company: ETU-Link Technology Co., LTD

Production base: Right side of 3rd floor, No. 102 building, Longguan expressway, Dalang street, Longhua District, Shenzhen city, Guangdong Province, China 518109

R&D base: Floor 4, Building 4, Nanshan Yungu Phase LI, Taoyuan Community, Xili Street, Nanshan District, Shenzhen

Tel: +86-755 2328 4603

Addresses and phone number also have been listed at www.etulinktechnology.com.

Please e-mail us at sales@etulinktechnology.com or call us for assistance.