

ESCxxX-80D

10Gb/s SFP+ CWDM 80km DDM Transceiver

PRODUCT FEATURES

- Support data rate up to 11.3Gb/s
- Hot-Pluggable SFP Footprint and Single LC Connector
- Up to 80km reach for G.652 SMF
- CWDM EML laser from 1471nm to 1611nm, with step 20nm and APD receiver
- Temperature Range:
 - Commercial: 0°C ~70°C
 - Industrial: -40°C ~85°C
- Low power consumption :<1.5W
- Compliant with SFP-8431
- Compliant with SFP-8432
- Compliant with SFP-8472
- Compliant with IEEE802.3ae
- RoHS 6 compliance
- Complies with EU Directive 2015/863/EU



APPLICATIONS

- 10G Ethernet
- OTU2/2e
- CPRI option 1,2,3,4,5,6,7,7A,8
- Other Optical Links

DESCRIPTIONS

This CWDM EML 10Gbps SFP+ transceiver is designed to transmit and receive optical data over single mode optical fiber for link length 80km.

The SFP+ 80km module electrical interface is compliant to SFI electrical specifications. The transmitter input and receiver output impedance is 100 Ohms differential. Data lines are internally AC coupled. The module provides differential termination and reduce differential to common mode conversion for quality signal termination and low EMI.

Ordering Information

Part No.	DataRate (optical)	Laser	Fiber Type	Distance	Optical Interface	Temp	DDMI
ESCxxX-80D	10.3125Gbps	EML	SMF	80km	LC	0~70°C	Y
ESCxxX-80DI	10.3125Gbps	EML	SMF	80km	LC	-40~85°C	Y

CWDM Wavelength

Band	xx	Wavelength (nm)			Latch Color
		Min.	Typ.	Max.	
S-band Short	47	1464.5	1471	1477.5	Gray
	49	1484.5	1491	1497.5	Purple
	51	1504.5	1511	1517.5	Blue
	53	1524.5	1531	1537.5	Green
C-band Conventional	55	1544.5	1551	1557.5	Yellow
L-band Long Wavelength	57	1564.5	1571	1577.5	Orange
	59	1584.5	1591	1597.5	Red
	61	1604.5	1611	1617.5	Brown

I.Absolute Maximum Ratings

Parameter	Symbol	Min.	Typical	Max.	Unit	Notes
Storage Temperature	T _{stg}	-40		+85	°C	

Case Operating Temperature(Commercial)	T_o	0		70	$^{\circ}\text{C}$	
Case Operating Temperature (Industrial)	T_o	-40		85	$^{\circ}\text{C}$	
Relative Humidity - Storage	R_{HS}	5		95	%	
Relative Humidity - Operating	R_{HO}	5		85	%	
DC Supply Voltage	V_{CC}	0		3.6	V	

II.Recommended Operating Conditions

Parameter	Symbol	Min.	Typical	Max.	Unit	Notes
Case Operating Temperature	T_{op}	0	-	70	$^{\circ}\text{C}$	Commercial
		-40		85		Industrial
Power Supply Voltage	V_{CC}	3.13	3.3	3.47	V	
Transmission Distance	TD	-	-	80	km	Over SMF

III.Electrical Characteristics

High-Speed Signal: Compliant to CEI-11G-SR

Low-Speed Signal: Compliant to SFF-8419

Parameter	Symbol	Min.	Typical	Max.	Unit	Notes	
Transmitter (Module Input)							
Differential Input Resistance	$R_{R_{din}}$	80	100	120	Ω		
Input Differential Voltage	$R_{V_{diff}}$	110	-	1050	mVpp		
Tx_Disable	Normal Operation	V_{IL}	-0.3	-	0.8	V	
	Laser Disable	V_{IH}	2.0	-	$V_{CC}+0.3$	V	
Receiver (Module Output)							
Differential Resistance	T_{R_d}	80	100	120	Ohm		
Output Differential Voltage	$T_{V_{diff}}$	360	-	770	mVpp		
Differential Termination Resistance Mismatch	$T_{R_{dm}}$	-	-	5	%		
Rx los	Normal Operation	V_{OL}	-0.3	-	0.4	V	
	Loss Signal	V_{OH}	2		V_{CCHOST}	V	

IV.Optical and Characteristics

Parameter	Symbol	Min.	Typical	Max.	Unit	Notes
Transmitter						
Average Output Power	POUT	0		6	dBm	1
Average Output Power(Laser Off)	POFF			-30	dBm	
Wavelength	λ	$\lambda-6.5$		$\lambda+6.5$	nm	

Spectrum Bandwidth @ -20dB	$\Delta\lambda$			1	nm	
Side mode suppression ratio(SMSR)	SMSR	30			dB	
Extinction ratio	ER	3.5			dB	
RIN20OMA	RIN			-128	dB/Hz	
Receiver						
Wavelength	λ	1260		1620	nm	
Received Sensitivity	P_{IN}			-23	dBm	BER<1x10 ⁻¹²
Optical Power Overload	P_{IN} (SAT)	-6			dBm	
Receiver Reflectance	RFL			-26	dB	
Rx_LOS of Signal Assert	P_A	-38			dBm	
Rx_LOS of Signal De-assert	P_D			-25	dBm	
Rx_LOS of Signal Hysteresis	PHy	0.5		5	dB	

Notes:

1. The optical power is launched into SMF.

V.Digital Diagnostics

Parameter	Range	Accuracy	Unit	Calibration
Temperature	-40 to 85	±3	°C	Internal
Voltage	0 to Vcc	±3%	V	Internal
Tx Bias Current	0 to 100	±10%	mA	Internal
Tx Output Power	0 to 6	±3	dBm	Internal
Rx Input Power	-25 to -5	±3	dBm	Internal

VI.Communication Interface Timing Characteristics

Parameter	Symbol	Min.	Typical	Max.	Unit	Notes
TX_Disable Assert Time	t _{off}			100	us	
TX_Disable Negate Time	t _{on}			2	ms	
Time to Initialize Include Reset of TX_FAULT	t _{int}			300	ms	
TX_FAULT from Fault to Assertion	t _{fault}			100	us	
TX_Disable Time to Start Reset	t _{reset}	10			us	
Receiver Loss of Signal Assert Time	T _{A,RX_LOS}			100	us	
Receiver Loss of Signal Deassert Time	T _{d,RX_LOS}			100	us	
Rate-Select Chage Time	t _{ratesel}			10	us	

VII.APD Diagram

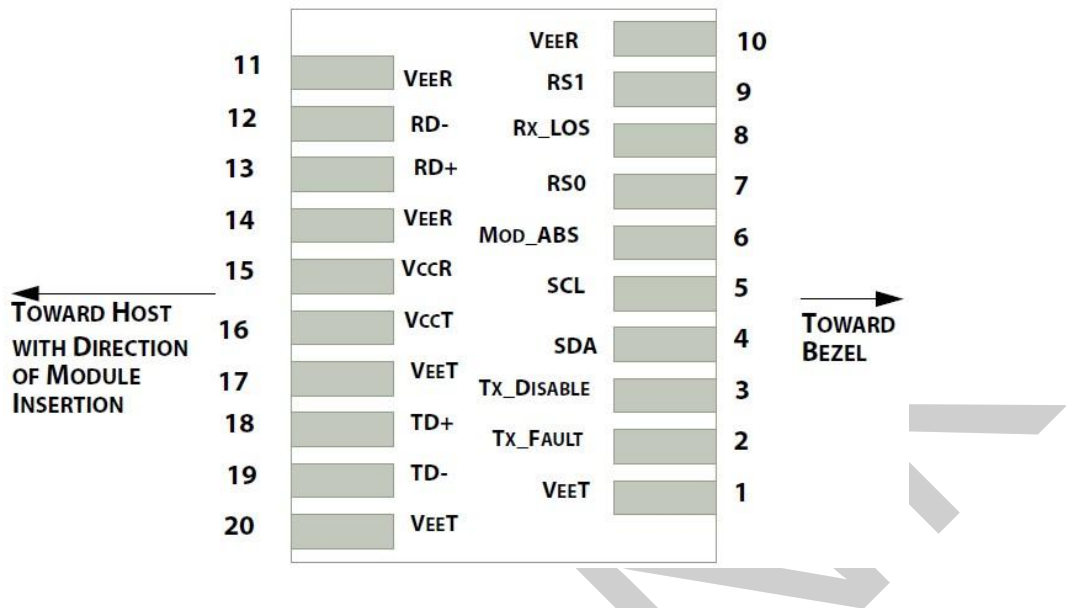

VIII.APD Definitions

APD #	Name	Function	Notes
1	VeeT	Module transmitter ground	1
2	Tx Fault	Module transmitter fault	2
3	Tx Disable	Transmitter Disable; Turns off transmitter laser output	3
4	SDL	2 wire serial interface data input/output (SDA)	4
5	SCL	2 wire serial interface clock input (SCL)	4
6	MOD-ABS	Module Absent, connect to VeeR or VeeT in the module	4
7	RS0	Rate select0, optionally control SFP+ receiver. When high, input data rate >4.5Gb/ s; when low, input data rate <=4.5Gb/s	5
8	LOS	Receiver Loss of Signal Indication	6
9	RS1	Rate select0, optionally control SFP+ transmitter. When high, input data rate >4.5Gb/s; when low, input data rate <=4.5Gb/s	1
10	VeeR	Module receiver ground	1
11	VeeR	Module receiver ground	1
12	RD-	Receiver inverted data output	
13	RD+	Receiver non-inverted data output	
14	VeeR	Module receiver ground	1
15	VccR	Module receiver 3.3V supply	
16	VccT	Module transmitter 3.3V supply	
17	VeeT	Module transmitter ground	1
18	TD+	Transmitter inverted data output	
19	TD-	Transmitter non-inverted data output	
20	VeeT	Module transmitter ground	1

Notes:

1. Circuit ground is internally isolated from chassis ground
2. Tx FAULT is an open collector/drain output, which should be pulled up with a 4.7k – 10k Ohms resistor on the host board if intended for use. Pull up voltage should be between 2.0V to Vcc + 0.3V. A high output indicates a transmitter fault caused by either the TX bias current or the TX output power exceeding the preset alarm thresholds. A low output indicates normal operation. In the low state, the output is pulled to <math><0.8V</math>.
3. Laser output disabled on Tx DIS >2.0V or open, enabled on Tx DIS <math><0.8V</math>.
4. Should be pulled up with 4.7k Ω - 10k Ω host board to a voltage between 2.0V and 3.6V. MOD_ABS pulls line low to indicate module is plugged in.
5. Internally pulled down per SFF-8431 Rev 4.1.
6. LOS is open collector output. It should be pulled up with 4.7k Ω – 10k Ω on host board to a voltage between 2.0V and 3.6V. Logic 0 indicates normal operation; logic 1 indicates loss of signal.

IX. Recommended Interface Circuit

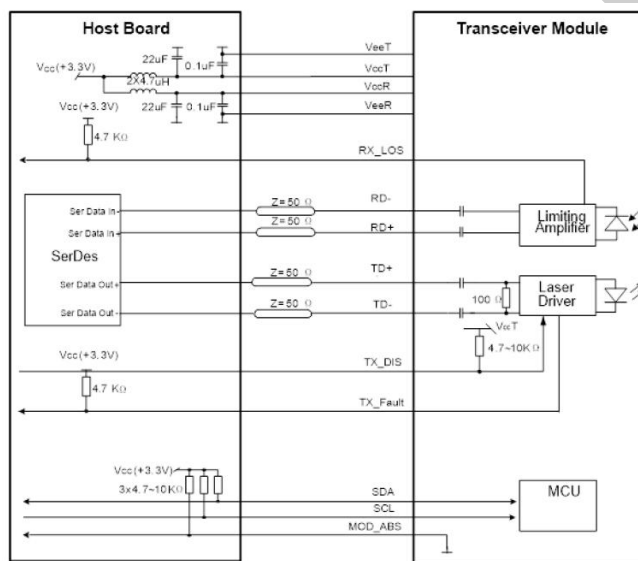

X. Mechanical Diagram

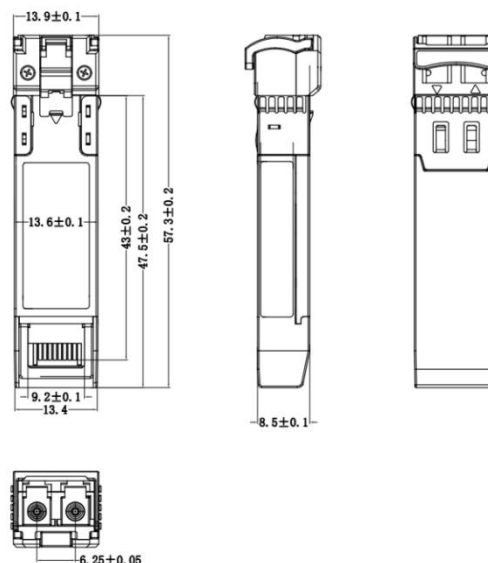

XI.Revision History

Version No.	Date	Description
1.0	February 8, 2016	Preliminary datasheet
2.0	October 11,2023	Product upgrades

Company: ETU-Link Technology Co., LTD

Address: Right side of 3rd floor, No. 102 building, Longguan expressway, Dalang street, Longhua District, Shenzhen city, Guangdong Province,China 518109

Tel: +86-755 2328 4603

Addresses and phone number also have been listed at www.etulinktechnology.com.

Please e-mail us at sales@etulinktechnology.com or call us for assistance.