

## ESDxx12-C0D(I)

1.25Gbps DWDM SFP Optical Transceiver, 120KM Reach

### PRODUCT FEATURES

- Wavelength selectable to C-band ITU-T grid wavelengths
- Suitable for use in 100GHz channel spacing DWDM systems
- DWDM SFP MSA Compliant
- Dual data-rate of 1.25Gbps/1.063Gbps operation
- OC-24 120km range
- Cold Start up Wavelength Compliance
- Low Power Dissipation <1.8W Maximum
- -5°C to 70°C Operating Case Temperature
- Diagnostic Performance Monitoring of module temperature, supply Voltages, laser bias current, transmit optical power, receive optical power, Laser temperature and TEC current
- Extended link budget with APD receiver technology
- RoHS compliant and lead free
- Interface: LC connector
- Operating case temperature:
  - Standard : 0 to +70°C
  - Industrial : -40 to +85°



### APPLICATIONS

- SFP Transceivers for DWDM SONET/ SDH
- Ethernet IEEE 802.3z
- Fiber Channel

## DESCRIPTIONS

ETU-Link DWDM SFP Transceiver exhibits excellent wavelength stability, supporting operation at 100GHz channel, cost effective module. It is designed for DWDM SONET/ SDH, Gigabit Ethernet and Fiber-Channel applications.

The transceiver consists of two sections: The transmitter section incorporates a colded DFB laser. And the receiver section consists of a APD photodiode integrated with a TIA. All modules satisfy class I laser safety requirements. ETU-Link DWDM SFP transceiver provides an enhanced monitoring interface, which allows real-time access to device operating parameters such as transceiver temperature, laser bias current, transmitted optical power, received optical power and transceiver supply voltage, laser temperature and TEC current.

## Module Block Diagram

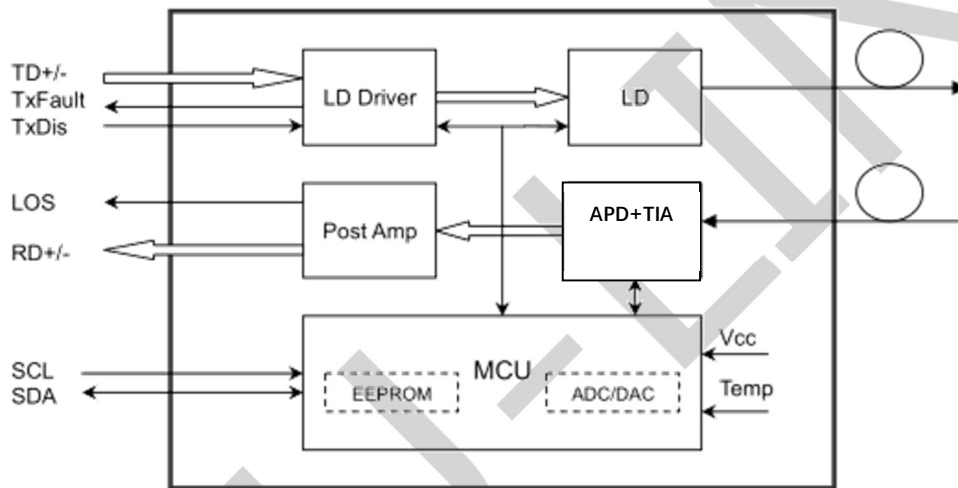

## Ordering Information

Part No.	Data Rate(optical)	Laser	Fiber Type	Distance	Optical Interface	Temp	DDMI
ESDxx12-C0D	1.25Gbps	EML	SMF	120KM	LC	0~70℃	Y
ESDxx12-C0D(I)	1.25Gbps	EML	SMF	120KM	LC	-40~85℃	Y

## Wavelength Selection

Code	Frequency (THz)	Center Wavelength(nm)	Code	Frequency (THz)	Center Wavelength(nm)
C17	191.7	1563.86	C40	194.0	1545.32

C18	191.8	1563.05	C41	194.1	1544.53
C19	191.9	1562.23	C42	194.2	1543.73
C20	192.0	1561.42	C43	194.3	1542.94
C21	192.1	1560.61	C44	194.4	1542.14
C22	192.2	1559.79	C45	194.5	1541.35
C23	192.3	1558.98	C46	194.6	1540.56
C24	192.4	1558.17	C47	194.7	1539.77
C25	192.5	1557.36	C48	194.8	1538.98
C26	192.6	1556.55	C49	194.9	1538.19
C27	192.7	1555.75	C50	195.0	1537.40
C28	192.8	1554.94	C51	195.1	1536.61
C29	192.9	1554.13	C52	195.2	1535.82
C30	193.0	1553.33	C53	195.3	1535.04
C31	193.1	1552.52	C54	195.4	1534.25
C32	193.2	1551.72	C55	195.5	1533.47
C33	193.3	1550.92	C56	195.6	1532.68
C34	193.4	1550.12	C57	195.7	1531.90
C35	193.5	1549.32	C58	195.8	1531.12
C36	193.6	1548.51	C59	195.9	1530.33
C37	193.7	1547.72	C60	196.0	1529.55
C38	193.8	1546.92	C61	196.1	1528.77
C39	193.9	1546.12			

## Absolute Maximum Ratings

It has to be noted that the operation in excess of any individual absolute maximum ratings might cause permanent damage to this module.

Parameter	Symbol	Min	Max	Unit	Notes
Storage Temperature	$T_s$	-40	85	°C	
Operating Case Temperature	$T_{case}$	See order Information		°C	
Power Supply Voltage	$V_{CC}$	-0.5	3.6	V	
Relative Humidity (non-condensation)	RH	5	95	%	
Damage Threshold	$TH_d$	5		dBm	

## Recommended Operating Conditions

Parameter	Symbol	Min	Typical	Max	Unit	Notes
Operating Case Temperature	T <sub>OP</sub>	0		70	°C	Commercial
		-40		85		Industrial
Power Supply Voltage	V <sub>CC</sub>	3.135	3.3	3.465	V	
Data Rate			1250		Mb/s	
Control Input Voltage High		2		V <sub>CC</sub>	V	
Control Input Voltage Low		0		0.8	V	
Link Distance (SMF)	D			120	km	9/125um

## Electrical Characteristics

Parameter	Symbol	Min.	Typical	Max	Unit	Notes
Power Consumption	P			1.5	W	commercial
				1.8		Industrial
Supply Current	I <sub>CC</sub>			450	mA	commercial
				545		Industrial
<b>Transmitter</b>						
Single-ended Input Voltage Tolerance	V <sub>CC</sub>	-0.3		4.0	V	
Differential Input Voltage Swing	V <sub>in,pp</sub>	200		2400	mVpp	
Differential Input Impedance	Z <sub>in</sub>	90	100	110	Ohm	
Transmit Disable Assert Time				5	us	
Transmit Disable Voltage	V <sub>dis</sub>	V <sub>CC</sub> -1.3		V <sub>CC</sub>	V	
Transmit Enable Voltage	V <sub>en</sub>	V <sub>EE</sub> -0.3		0.8	V	
<b>Receiver</b>						
Differential Output Voltage Swing	V <sub>out,pp</sub>	500		900	mVpp	
Differential Output Impedance	Z <sub>out</sub>	90	100	110	Ohm	

Data output rise/fall time	Tr/Tf		100	260	ps	20% to 80%
LOS Assert Voltage	VlosH	Vcc-1.3		Vcc	V	
LOS De-assert Voltage	VlosL	Vee-0.3		0.8	V	

Note:

Note (1): A (TX) + B (RX) = 500mA (Not include termination circuit)

### Optical and Characteristics

Parameter	Symbol	Min	Typ	Max	Unit	Ref.
<b>Transmitter</b>						
Center Wavelength Spacing			100		GHz	
Center Wavelength	$\lambda$	X-100	X	X+100	pm	Note (1)
Average Output Power	POUT	0		5	dBm	
Extinction Ratio	ER	9			dB	
Side Mode Suppression Ratio	SMSR	30			dB	
Spectrum Bandwidth(-20dB)	$\sigma$			1	nm	
Transmitter OFF Output Power	POff			-45	dBm	
Differential Line Input Impedance	RIN	90	100	110	Ohm	
Output Eye Mask	Compliant with IEEE 802.3 Z					Note (2)

Note:

Note (1): X = specified ITU center wavelength. (To See "Ordering Information")

Note (2): Transmitter eye mask definition.

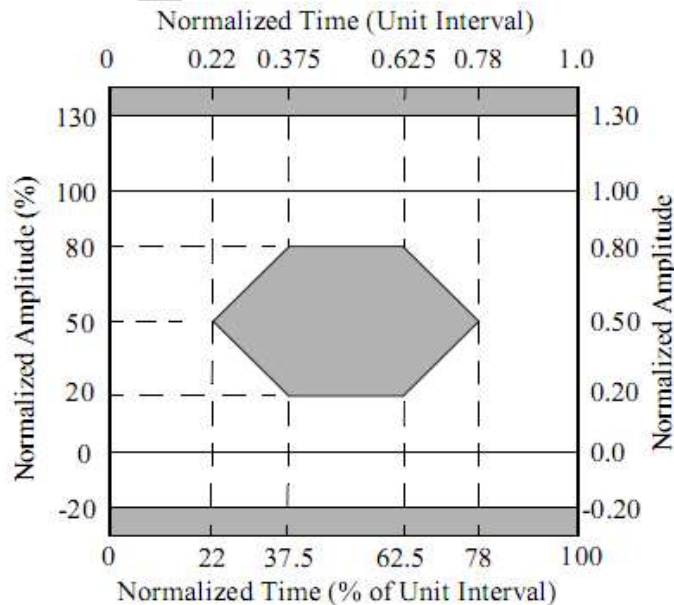

Parameter	Symbol	Min	Typ	Max	Unit	Ref.
<b>Receiver</b>						
Input Optical Wavelength	$\lambda_{IN}$	1270		1610	nm	APD
Receiver Sensitivity	PIN			-30	dBm	Note (1)
Input Saturation Power (Overload)	PSAT	-3			dBm	
Los Of Signal Assert	PA	-45			dBm	
Los Of Signal De-assert	PD			-31	dBm	Note (2)
LOS Hysteresis	PA-PD	0.5	2	6	dB	

Note:

Note (1): Measured with Light source 1550nm, ER=9dB; BER  $\leq 10^{-12}$  @PRBS=2<sup>7</sup>-1 NRZ

Note (2): When LOS de-asserted, the RX data+/- output is High-level (fixed).

## Digital Diagnostics

ETU-LINK ESDxx12-C0D(I) transceivers support the 2-wire serial communication protocol as defined in the SFP MSA. It is very closely related to the E2PROM defined in the GBIC standard, with the same electrical specifications.

The standard SFP serial ID provides access to identification information that describes the transceiver's capabilities, standard interfaces, manufacturer, and other information.

Additionally, ETU-LINK SFP transceivers provide a unique enhanced digital diagnostic monitoring interface, which allows real-time access to device operating parameters such as transceiver temperature, laser bias current, transmitted optical power, received optical power and transceiver supply voltage. It also defines a sophisticated system of alarm and warning flags, which alerts end-users when particular operating parameters are outside of a factory set normal range.

The SFP MSA defines a 256-byte memory map in E2PROM that is accessible over a 2-wire serial interface at the 8 bit address 1010000X (A0h). The digital diagnostic monitoring interface makes use of the 8 bit address 1010001X (A2h), so the originally defined serial ID memory map remains unchanged. The interface is identical to, and is thus fully backward compatible with both the GBIC Specification and the SFP Multi Source Agreement.

The operating and diagnostics information is monitored and reported by a Digital Diagnostics Transceiver Controller (DDTC) inside the transceiver, which is accessed through a 2-wire serial interface. When the serial protocol is activated, the serial clock signal (SCL, Mod Def 1) is generated by the host. The positive edge clocks data into the SFP transceiver into those segments of the E2PROM that are not write-protected. The negative edge clocks data from the SFP transceiver. The serial data signal (SDA, Mod Def 2) is bi-directional for serial data transfer. The host uses SDA in conjunction with SCL to mark the start and end of serial protocol activation. The memories are organized

as a series of 8-bit data words that can be addressed individually or sequentially.

Digital diagnostics for the ESDxx12-C0D are internally calibrated by default.

## Pin Diagram

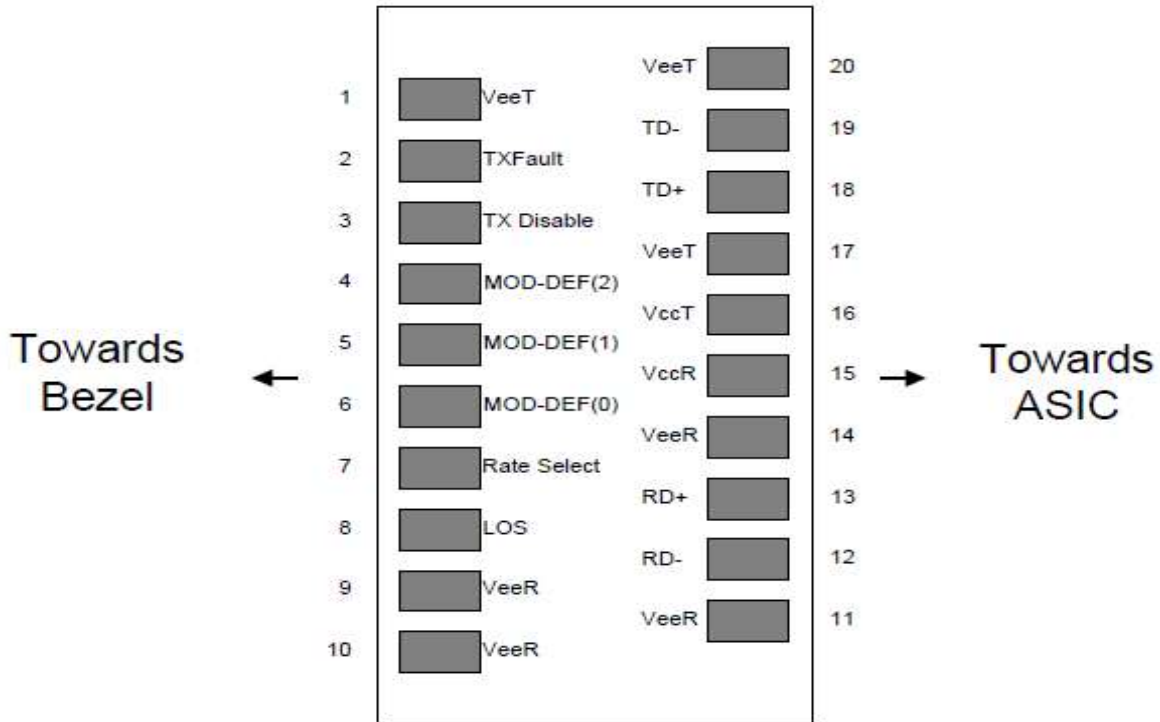

## Pin Definitions

Pin	Symbol	Name/Description	Ref.
1	VEET	Transmitter Ground (Common with Receiver Ground)	1
2	TFAULT	Transmitter Fault.	
3	TDIS	Transmitter Disable. Laser output disabled on high or open.	2
4	MOD_DEF(2)	Module Definition 2. Data line for Serial ID.	3
5	MOD_DEF(1)	Module Definition 1. Clock line for Serial ID.	3
6	MOD_DEF(0)	Module Definition 0. Grounded within the module.	3
7	Rate Select	No connection required	4
8	LOS	Loss of Signal indication. Logic 0 indicates normal operation.	5

9	VEER	Receiver Ground (Common with Transmitter Ground)	1
10	VEER	Receiver Ground (Common with Transmitter Ground)	1
11	VEER	Receiver Ground (Common with Transmitter Ground)	1
12	RD-	Receiver Inverted DATA out. AC Coupled	
13	RD+	Receiver Non-inverted DATA out. AC Coupled	
14	VEER	Receiver Ground (Common with Transmitter Ground)	1
15	VCCR	Receiver Power Supply	
16	VCCT	Transmitter Power Supply	
17	VEET	Transmitter Ground (Common with Receiver Ground)	1
18	TD+	Transmitter Non-Inverted DATA in. AC Coupled.	
19	TD-	Transmitter Inverted DATA in. AC Coupled.	
20	VEET	Transmitter Ground (Common with Receiver Ground)	1

## Notes:

- Circuit ground is internally isolated from chassis ground.
- Laser output disabled on  $T_{DIS} > 2.0V$  or open, enabled on  $T_{DIS} < 0.8V$ .
- Should be pulled up with 4.7k - 10kohms on host board to a voltage between 2.0V and 3.6V. MOD\_DEF (0) pulls line low to indicate module is plugged in.
- This is an optional input used to control the receiver bandwidth for compatibility with multiple data rates (most likely Fiber Channel 1x and 2x Rates). If implemented, the input will be internally pulled down with  $> 30k\Omega$  resistor. The input states are:
  - Low (0 – 0.8V): Reduced Bandwidth
  - (>0.8, < 2.0V): Undefined
  - High (2.0 – 3.465V): Full Bandwidth
  - Open: Reduced Bandwidth
- LOS is open collector output should be pulled up with 4.7k - 10kohms on host board to a voltage between 2.0V and 3.6V. Logic 0 indicates normal operation; logic 1 indicates loss of signal.



### Recommended Interface Circuit

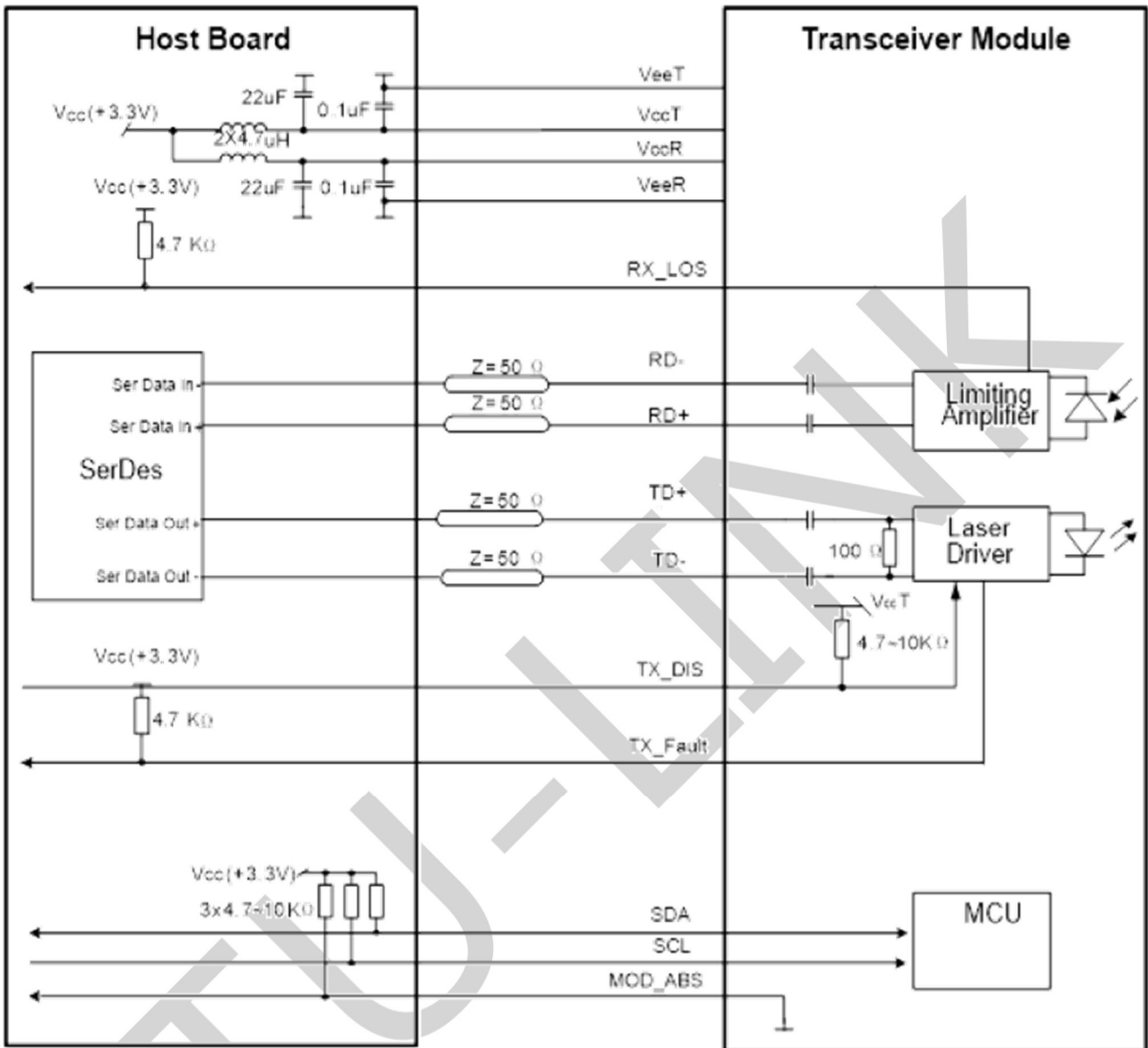

## Mechanical Diagram

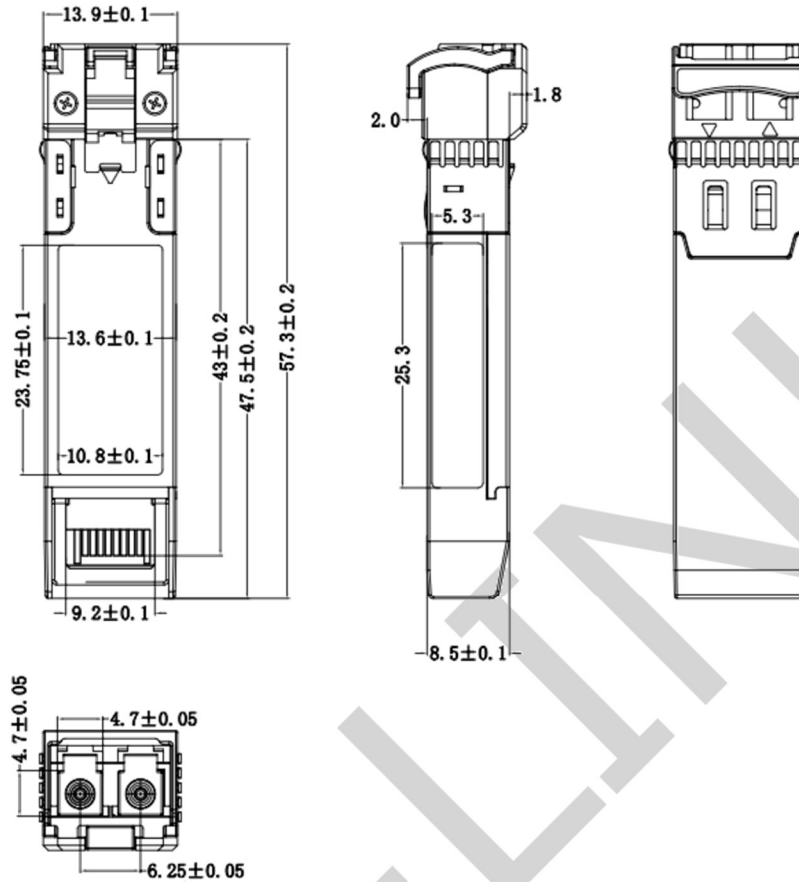

## Revision History

Version No.	Date	Description
1.0	February 18, 2016	Preliminary datasheet
2.0	September 28, 2023	Product upgrades
3.0	July 26, 2024	Format change

Company: ETU-Link Technology Co., LTD

Production base: Right side of 3rd floor, No. 102 building, Longguan expressway, Dalang street, Longhua District, Shenzhen city, Guangdong Province, China 518109

R&D base: Floor 4, Building 4, Nanshan Yungu Phase LI, Taoyuan Community, Xili Street, Nanshan District, Shenzhen

Tel: +86-755 2328 4603

Addresses and phone number also have been listed at [www.etulinktechnology.com](http://www.etulinktechnology.com).

Please e-mail us at [sales@etulinktechnology.com](mailto:sales@etulinktechnology.com) or call us for assistance.