

Rev	Date	Modified by	Description
A0	2023		

## Product Specifications

### 10Gb/s SFP+ DWDM 40km DDM Transceiver

**PN: ESDxxX-3LCD40**

#### Features

- Support data rate up to 11.3Gb/s
- Hot-Pluggable SFP Footprint and Duplex LC Connector
- Up to 40km reach for G.652 SMF
- Available in all C-Band Wavelengths on the 100GHz DWDM ITU Grid
- Temperature-Stabilized DWDM EML Transmitter and PIN Receiver
- Temperature Range:
  - Commercial: 0° C ~70° C
  - Industrial: -40° C ~85° C
- Power consumption:
  - Commercial: 1.5W
  - Industrial: 1.8W
- Compliant with SFP-8431
- Compliant with SFP-8432
- Compliant with SFP-8472
- Compliant with IEEE802.3ae
- RoHS 6 compliance
- Complies with EU Directive 2015/863/EU



#### Applications

- 10G Ethernet
- OTU2/2e
- 10G FC
- Other Optical Links

## PRODUCT DESCRIPTION

The ESDxxX-3LCD40 series single mode transceiver is small form factor pluggable module for duplex optical data communications such as 10GBASE-LR defined by IEEE 802.3. The ESDxxX-40D(I) module is designed for single mode fiber and operates at a nominal wavelength of 1528.77nm to 1563.86nm; the transmitter section uses a multiple quantum well EML, which is class 1 laser compliant according to International Safety Standard IEC-60825.

The SFP+ 40km module electrical interface is compliant to SFI electrical specifications. The transmitter input and receiver output impedance is 100 Ohms differential. Data lines are internally AC coupled. The module provides differential termination and reduce differential to common mode conversion for quality signal termination and low EMI.

## Wavelength Guide Table

Channel	Wavelength(nm)	Frequency(THz)	Channel	Wavelength(nm)	Frequency(THz)
C12	1567.95	191.20	C42	1543.73	194.20
C13	1567.13	191.30	C43	1542.94	194.30
C14	1566.31	191.40	C44	1542.14	194.40
C15	1565.50	191.50	C45	1541.35	194.50
C16	1564.68	191.60	C46	1540.56	194.60
C17	1563.86	191.70	C47	1539.77	194.70
C18	1563.05	191.80	C48	1538.98	194.80
C19	1562.23	191.90	C49	1538.19	194.90
C20	1561.42	192.00	C50	1537.40	195.00
C21	1560.61	192.10	C51	1536.61	195.10
C22	1559.79	192.20	C52	1535.82	195.20
C23	1558.98	192.30	C53	1535.04	195.30
C24	1558.17	192.40	C54	1534.25	195.40
C25	1557.36	192.50	C55	1533.47	195.50
C26	1556.55	192.60	C56	1532.68	195.60
C27	1555.75	192.70	C57	1531.90	195.70
C28	1554.94	192.80	C58	1531.12	195.80
C29	1554.13	192.90	C59	1530.33	195.90
C30	1553.33	193.00	C60	1529.55	196.00
C31	1552.52	193.10	C61	1528.77	196.10
C32	1551.72	193.20	C62	1527.99	196.20
C33	1550.92	193.30	C63	1527.22	196.30
C34	1550.12	193.40	C64	1526.44	196.40

C35	1549.32	193.50	C65	1525.66	196.50
C36	1548.51	193.60	C66	1524.89	196.60
C37	1547.72	193.70	C67	1524.11	196.70
C38	1546.92	193.80	C68	1523.34	196.80
C39	1546.12	193.90	C69	1522.56	196.90
C40	1545.32	194.00	C70	1521.79	197.00
C41	1544.53	194.10			

## Absolute Maximum Ratings

Parameter	Symbol	Min.	Typical	Max.	Unit
Storage Temperature	T <sub>stg</sub>	-40		+85	°C
Case Operating Temperature(Commercial)	T <sub>o</sub>	0		70	°C
Case Operating Temperature (Industrial)	T <sub>o</sub>	-40		85	°C
Relative Humidity - Storage	R <sub>HS</sub>	5		95	%
Relative Humidity - Operating	R <sub>HO</sub>	5		85	%
DC Supply Voltage	V <sub>CC</sub>	0		3.6	V

## Recommended Operating Conditions

Parameter	Symbol	Min.	Typical	Max.	Unit	Notes
Case Operating Temperature	T <sub>op</sub>	0	-	70	°C	Commercial
		-40		85		Industrial
Power Supply Voltage	V <sub>CC</sub>	3.13	3.3	3.47	V	
Transmission Distance	TD	-	-	40	km	Over SMF

## Electrical Characteristics

High-Speed Signal: Compliant to CEI-11G-SR

Low-Speed Signal: Compliant to SFF-8431

Parameter	Symbol	Min.	Typical	Max.	Unit	Notes
Supply Voltage	V <sub>CC</sub>	3.135		3.465	V	
Supply Current	I <sub>CC</sub>			450	mA	Commercial
				540		Industrial
Power Consumption	P			1.5	W	Commercial
				1.8		Industrial
<b>Transmitter (Module Input)</b>						

Differential Input Resistance		R_R <sub>din</sub>	80	100	120	Ω	
Input Differential Voltage		R_V <sub>diff</sub>	110	-	1050	mVpp	
Tx_Disable	Normal Operation	V <sub>IL</sub>	-0.3	-	0.8	V	
	Laser Disable	V <sub>IH</sub>	2.0	-	V <sub>CC</sub> +0.3	V	
<b>Receiver (Module Output)</b>							
Differential Resistance		T_R <sub>d</sub>	80	100	120	Ohm	
Output Differential Voltage		T_V <sub>diff</sub>	360	-	770	mVpp	
Differential Termination Resistance Mismatch		T_R <sub>d</sub> m	-	-	5	%	
Rx los	Normal Operation	V <sub>OL</sub>	-0.3	-	0.4	V	
	Loss Signal	V <sub>OH</sub>	2		V <sub>CC</sub> H <sub>OST</sub>	V	

## Optical Characteristics

Parameter	Symbol	Min.	Typical	Max.	Unit	Notes
<b>Transmitter</b>						
Average Output Power	POUT	-1		4	dBm	1
Average Output Power(Laser Off)	POFF			-30	dBm	
Wavelength	λ	λ-0.1		λ+0.1	nm	
Center Wavelength Spacing			100		GHz	4
Spectrum Bandwidth @ -20dB	Δλ			1	nm	
Side mode suppression ratio(SMSR)	SMSR	30			dB	
Extinction ratio	ER	8.2			dB	
RIN <sub>20</sub> OMA	RIN			-128	dB/Hz	2
<b>Receiver</b>						
Wavelength	λ	1270		1610	nm	
Received Sensitivity	P <sub>IN</sub>			-16	dBm	3
Optical Power Overload	P <sub>IN</sub> (SAT)	0			dBm	
Rx_LOS of Signal Assert	P <sub>A</sub>	-30			dBm	
Rx_LOS of Signal De-assert	P <sub>D</sub>			-17	dBm	
Rx_LOS of Signal Hysteresis	P <sub>Hy</sub>	0.5			dB	

Notes:

1. Output is coupled into a 9/125um SMF.
2. 12dB reflection.
3. Measured with worst ER, BER less than 1E-12 and PRBS 2<sup>31</sup>-1 at 10.3125Gbps.
4. Corresponds to approximately 0.8 nm.

## Digital Diagnostic

Parameter	Range	Accuracy	Unit	Calibration
Temperature	-40 to 85	±3	°C	Internal
Voltage	0 to Vcc	±3%	V	Internal
Tx Bias Current	30 to 100	±10%	mA	Internal
Tx Output Power	-1 to 4	±3	dB	Internal
Rx Input Power	-16 to 0	±3	dB	Internal

## Communication Interface Timing Characteristics

Parameter	Symbol	Min.	Typical	Max.	Unit	Notes
TX_Disable Assert Time	t_off			100	us	
TX_Disable Negate Time	t_on			2	ms	
Time to Initialize Include Reset of TX_FAULT	t_int			300	ms	
TX_FAULT from Fault to Assertion	t_fault			100	us	
TX_Disable Time to Start Reset	t_reset	10			us	
Receiver Loss of Signal Assert Time	T <sub>A,RX_LOS</sub>			100	us	
Receiver Loss of Signal Deassert Time	T <sub>d,RX_LOS</sub>			100	us	
Rate-Select Chage Time	t_ratesel			10	us	

## Pin Diagram

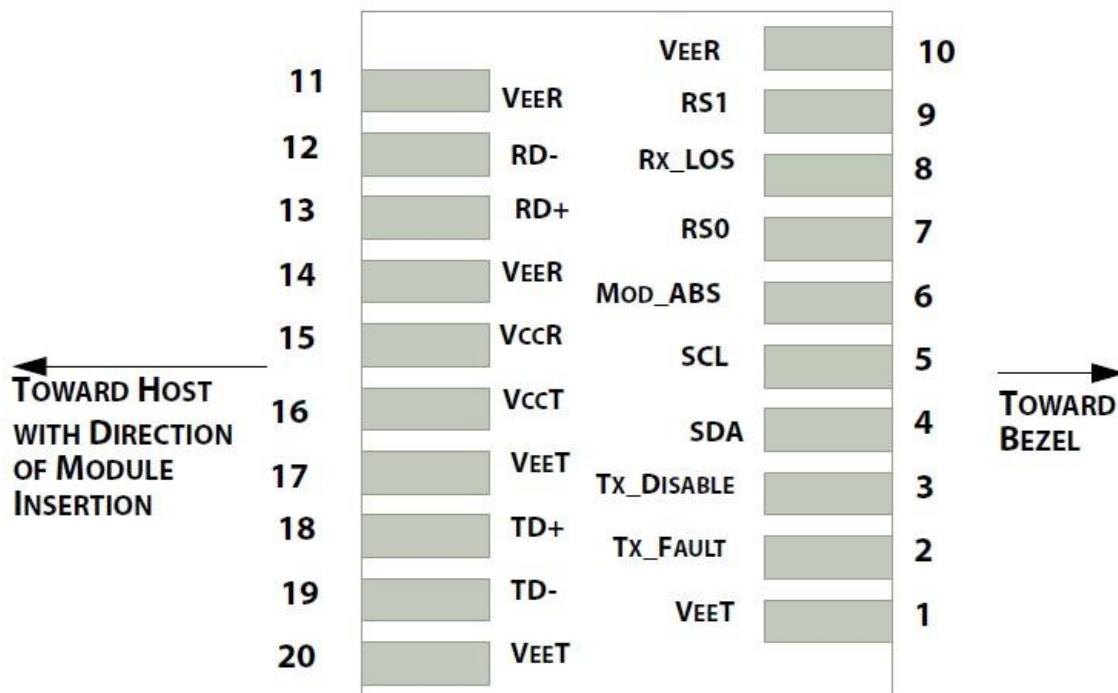

## Pin Definitions

PIN #	Name	Function	Notes
1	VeeT	Module transmitter ground	1
2	Tx Fault	Module transmitter fault	2
3	Tx Disable	Transmitter Disable; Turns off transmitter laser output	3
4	SDL	2 wire serial interface data input/output (SDA)	4
5	SCL	2 wire serial interface clock input (SCL)	4
6	MOD-ABS	Module Absent, connect to VeeR or VeeT in the module	4
7	RS0	Rate select0, optionally control SFP+ receiver. When high, input data rate >4.5Gb/s; when low, input data rate <=4.5Gb/s	5
8	LOS	Receiver Loss of Signal Indication	6
9	RS1	Rate select0, optionally control SFP+ transmitter. When high, input data rate >4.5Gb/s; when low, input data rate <=4.5Gb/s	1
10	VeeR	Module receiver ground	1
11	VeeR	Module receiver ground	1
12	RD-	Receiver inverted data output	
13	RD+	Receiver non-inverted data output	
14	VeeR	Module receiver ground	1
15	VccR	Module receiver 3.3V supply	
16	VccT	Module transmitter 3.3V supply	
17	VeeT	Module transmitter ground	1
18	TD+	Transmitter inverted data output	
19	TD-	Transmitter non-inverted data output	
20	VeeT	Module transmitter ground	1

### Notes:

1. Circuit ground is internally isolated from chassis ground
2. Tx FAULT is an open collector/drain output, which should be pulled up with a 4.7k – 10k Ohms resistor on the host board if intended for use. Pull up voltage should be between 2.0V to Vcc + 0.3V. A high output indicates a transmitter fault caused by either the TX bias current or the TX output power exceeding the preset alarm thresholds. A low output indicates normal operation. In the low state, the output is pulled to <0.8V.
3. Laser output disabled on Tx DIS >2.0V or open, enabled on Tx DIS <0.8V.
4. Should be pulled up with 4.7kΩ- 10kΩ host board to a voltage between 2.0V and 3.6V. MOD\_ABS pulls line low to indicate module is plugged in.
5. Internally pulled down per SFF-8431 Rev 4.1.
6. LOS is open collector output. It should be pulled up with 4.7kΩ – 10kΩ on host board to a voltage between 2.0V and 3.6V. Logic 0 indicates normal operation; logic 1 indicates loss of signal.

## Recommend Interface Circuit

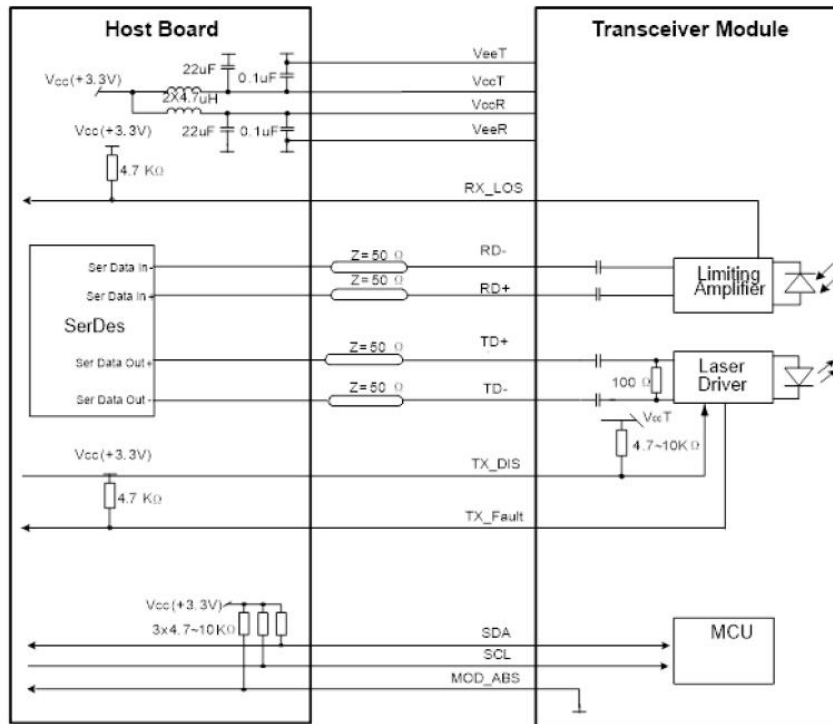

## Mechanical Diagram

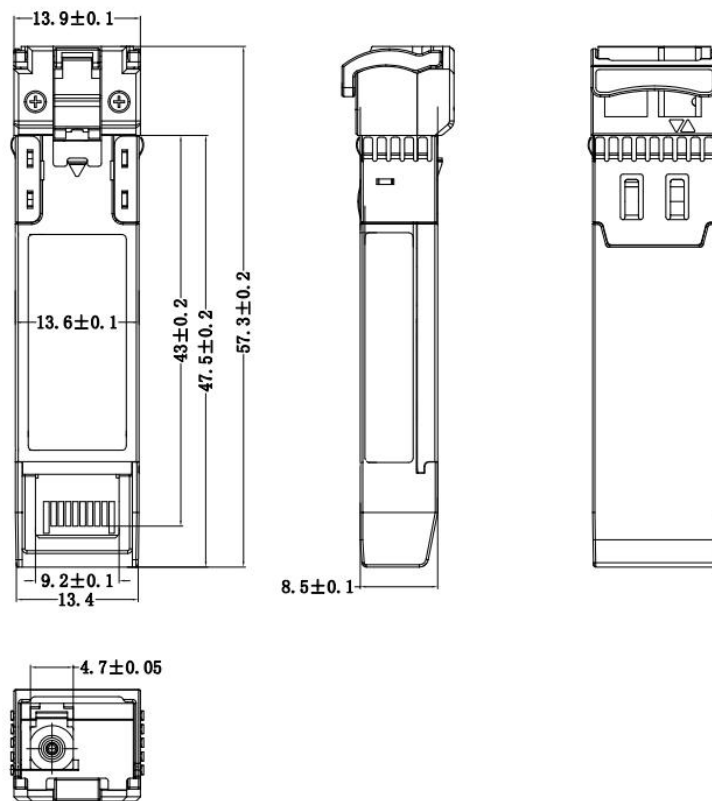



## Ordering information

Part No.	Data Rate(optical)	Laser	Fiber Type	Distance	Optical Interface	Temp	DDMI
ESDxxX-3LCD40	10.3125Gbps	EML	SMF	40km	LC	0~70°C	Y
ESDxxX-3LID40	10.3125Gbps	EML	SMF	40km	LC	-40~85°C	Y

## Compatibility Test

In order to ensure the product compatibility, our products will be tested on the switch before shipment. Our modules can compatible with many mainstream brand switches, such as Cisco, Juniper, Extreme, Brocade, IBM, H3C, HP, Huawei, D-Link, Mikrotik, ZTE, TP-Link...

Our test equipment: VOLKTEK MEN-4110, HP 2530-8G, CRS226-24G-25+RM, Catalyst 2960G Series, Catalyst 3850 XS 10G SFP+, Catalyst 3750-E Series, HUAWEI S5700Series, H3C S3100V2 Series, Juniper-EX4200, etc.

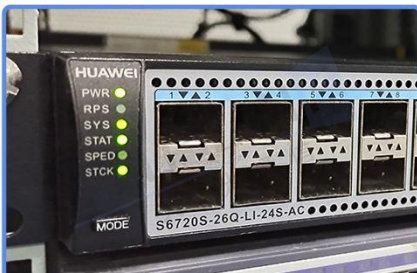

HUAWEI S6720S

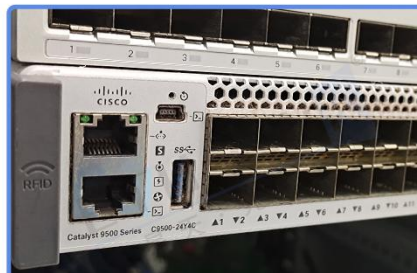

CISCO Catalyst 9500



DELL S5048F



H3C S3100V2

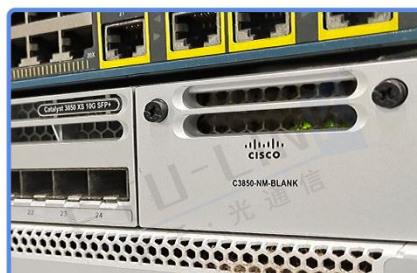

CISCO C3850



Aruba 2930F



Juniper EX 4200



HP J9264A



Quidway S5700



## Product Production Process

# Quality Assurance

Continuous introduction of new equipment,  
produced by strict standards, strict quality inspection,  
to guarantee the high quality, standard of each product.

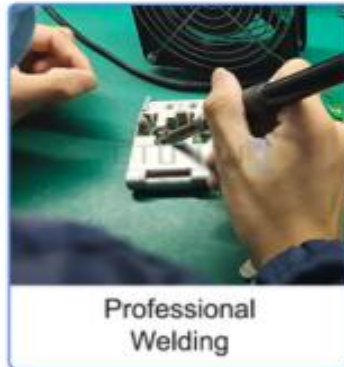

## Packaging

ETU-Link provides two kinds of packaging, 10pcs/Tray and individual package.



Company: ETU-Link Technology Co., LTD

Address: Right side of 3rd floor, No. 102 building, Longguan expressway, Dalang street,  
Longhua District, Shenzhen city, Guangdong Province, China 518109

Tel: +86-755 2328 4603

Addresses and phone number also have been listed at [www.etulinktechnology.com](http://www.etulinktechnology.com).

Please e-mail us at [sales@etulinktechnology.com](mailto:sales@etulinktechnology.com) or call us for assistance.